



---

# **T2000 Programming Application User's Manual**

---

**October 2002  
M2000-00-003-806**

**CONNECTIVITY • RELIABILITY • FLEXIBILITY**

**TAIT  
T2000  
MOBILES**



# Contents

---

<b>Part A: Getting Started .....</b>	<b>1</b>
Installation .....	3
Minimum System Requirements .....	3
Equipment Supplied .....	3
Application Installation .....	3
Connecting a Radio to your PC .....	3
Reading and Programming T2000 Radios .....	4
Reading a Radio .....	4
Opening a Radio Programming Database .....	4
Creating a New Database .....	5
Programming a Radio .....	5
Select a Different Radio Model .....	5
Changing Access Levels .....	6
Navigating Between Forms .....	6
Application Menu Commands .....	7
File Menu .....	7
Edit Menu .....	8
Radio Menu .....	9
Network Menu .....	10
Tools Menu .....	11
Help Menu .....	11
Changing Data .....	13
Text Box .....	13
Combo Box .....	13
Check Box .....	14
Grids .....	14
Transferring Data .....	15
Copying Data Into Grids From Excel .....	15
Copying Fields .....	15
<b>Part B: Getting and Using Help .....</b>	<b>17</b>
Getting and Using Help .....	19
Online Help .....	19
What's This? Help .....	19
Help on the Internet .....	19
<b>Part C: Programming Conventional Features .....</b>	<b>21</b>
What's New - T2000 Conventional Radios .....	23
Basic Radio Settings .....	24
Specifications (Conventional) Form .....	24
Receiver Monitoring Form .....	26
Transmitter Setup Form .....	28
Setting Up Signalling Options .....	30
Subaudible Signalling Form .....	30
Signalling Tab .....	30
Presets Tab .....	31
Selcall Identity Form .....	32
Selcall Identity Tab .....	32
Selcall Setup Tab .....	36
Selcall Sequences Tab .....	39

Selcall Features Form .....	40
Selcall Status Form .....	41
Selcall Emergency Form .....	43
Setting Up Channels and Scan Groups .....	46
Channels Form .....	46
Scan Groups Form .....	48
Scan Group Members Grid .....	49
Scan Settings .....	50
Enhanced Scan Form .....	51
Enhanced Scanning Grid .....	52
Birdie Channels Form .....	52
Special Features .....	54
Power Saving (Conventional) Form .....	54
DTMF Form .....	54
Alpha Symbols Form .....	56
CCI Setup (Conventional) Form .....	57
Radio Interface Options .....	59
Key Settings Form .....	59
User Selectable Form .....	61

## **Part D: Programming Trunked Features ..... 65**

What's New - T2000 Trunked Radios .....	67
Programming Trunked Radios .....	68
Programming Sequence .....	68
Working with Multiple Networks .....	68
Setting up a network template .....	68
Importing a network .....	69
Specifications (Trunked) Form .....	69
Radio Model Information .....	69
Installed Options .....	71
ESN .....	72
Network .....	72
Startup .....	72
Identity .....	73
Changing Network Settings .....	74
Trunked Channel Blocks Form .....	74
Network Identity Form .....	75
Network Parameters Form .....	77
Control Channel Acquisition/Retention .....	77
Signalling Parameters .....	78
Background Hunt Parameters .....	79
Hunting Parameters Form .....	79
Normal Hunt Channels Grid .....	80
Non Applicable Channels Grid .....	80
Parameters .....	81
ANN Interfleet Form .....	81
Changing Fleet Settings .....	83
Fleet Identity Form .....	83
Settings .....	83
Fleet Structure Definition .....	84
Fleet Parameters Form .....	86
Conventional Channels (Trunked) Form .....	87
Changing Radio Unit Settings .....	89
Radio Unit ID Form .....	89

Identity .....	89
Group Membership Grid .....	90
Restrict Calls .....	91
Settings .....	92
Acquisition Data Form .....	92
Acquisition Authorisation Grid .....	92
NDD Preference Data Grid .....	93
Zones .....	93
CCI Setup (Trunked) Form .....	94
Data Parameters Form .....	95
Short Data Messages .....	95
Tait Data Protocol .....	96
Status Messages Form .....	97
Power Saving (Trunked) Form .....	97
Preset Calls Form .....	99
5 Digit Lookup Form .....	100
External Calls Form .....	101
Call Options Form .....	102
External Alert Form .....	105
Key Settings (Trunked) Form .....	107
Interface Options Form .....	108
Initial Settings .....	108
Call Initiation .....	108
DTMF .....	109
Diagnostics .....	109
Audible Indicators .....	109
<b>Part E: Concepts .....</b>	<b>111</b>
Introduction to Channels and Scan Groups .....	113
Squelch and Signalling: Filtering Out Unwanted Noise and Traffic .....	113
Squelch .....	113
Signalling .....	113
Selcall .....	115
Monitor: Listening In On Channel Traffic .....	116
Introduction to Scan Groups .....	116
Scanning .....	116
Voting .....	117
Introduction to Trunking .....	119
Control Channel Communication .....	119
Early Trunking Systems .....	120
Addressing .....	121
MPT 1327 Numbering .....	122
MPT 1343 Numbering .....	122
CPSX Dialling .....	123
Trunking Call Strings .....	126
<b>Part F: Troubleshooting .....</b>	<b>129</b>
No appropriate licence to use this functionality .....	131
Cannot see the forms tree .....	131
Cannot find a field .....	131
Cannot enable a field .....	131
Radio won't read or program .....	131
Checksum Error .....	131
Subaudible Signalling Does Not Work .....	131

Scanning Does Not Work .....131

**Glossary ..... 133**

**Index ..... 167**

# Part A Getting Started

This part describes how to get started using the T2000 Programming Application.

## Topics

- [Installation](#)
- [Reading and Programming T2000 Radios](#)
- [Application Menu Commands](#)
- [Changing Data](#)
- [Transferring Data](#)





# Installation

---

Before you can begin reading and programming radios using the T2000 programming application, you must install the required software and hardware.

## Minimum System Requirements

The application requires the following minimum configuration:

- an IBM compatible PC with a Pentium 100 microprocessor (Pentium 166 recommended)
- Windows® 95, Windows 98, Windows 2000 or Windows NT® 4
- 32 MB of RAM (64 MB recommended)
- a VGA colour graphics display (600 x 800 resolution recommended)
- a hard disk drive with 35 MB of free space
- CD-ROM drive
- a Microsoft or compatible mouse and driver (if you wish to use the program with a mouse)
- a free serial port for connection to the radio

## Equipment Supplied

- application CD
- radio programming cable with a 9 or 25-pin serial connector at one end and an RJ-11 telephone-style plug at the other



**Note:** If your serial connector is 25-pin and your computer has a 9-pin serial port, you will need an adaptor. This is available from your PC dealer.

## Application Installation

To install the application:

1. Insert the installation CD into your CD-ROM drive.
2. If the autorun does not automatically start, select Start > Run.
3. Type “D:\setup.exe” where “D” is the letter that identifies the CD-ROM drive containing the install CD.
4. Click OK.

The installation program will guide you through the installation process. Read the information presented on the screen carefully.

## Connecting a Radio to your PC

To connect a T2000 radio to your PC:

1. Connect the radio programming cable’s 9 or 25 pin connector to the computer’s serial port.
2. Connect the radio programming cable’s RJ-11 telephone-style plug to the radio’s microphone socket.



**Tip:** You can change the COM port the application uses to communicate with the radio using the Tools > [Options](#) command.

# Reading and Programming T2000 Radios

When you first start the T2000 Programming Application, the main window appears with the default data file loaded:

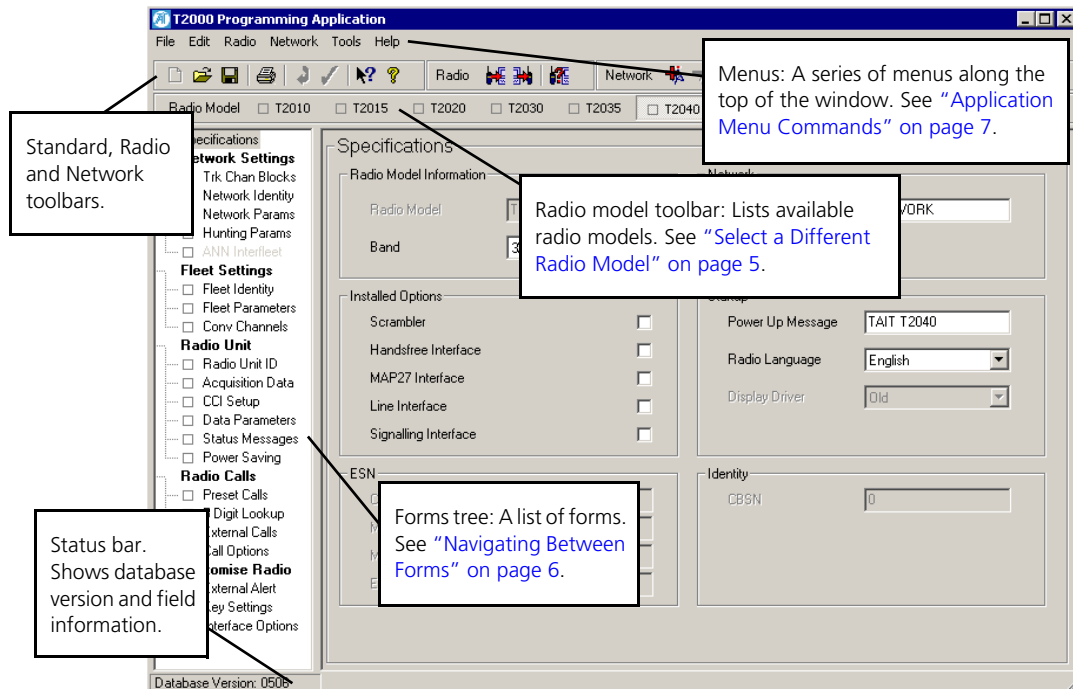

A common workflow in the programming application is to:

1. read a radio, or open a radio programming database file
2. change settings using the various forms, then
3. program one or more radios.

## Reading a Radio

To read a radio:

1. Connect a radio to your PC. See ["Connecting a Radio to your PC" on page 3](#) for more information.
2. Make sure the radio is connected to a power source and the power is on.
3. Switch the radio on.
4. Select the Radio > Read menu option, or select the Read button  from the toolbar.

As the programming database is read from the radio, the application indicates the radio model, and the software and database version numbers.

## Opening a Radio Programming Database

To open a radio programming database file saved to disk:

- select File > Open or
- select the Open button  from the toolbar or
- drag a file from an open window outside the application onto the left pane (forms tree) of the application.

## Creating a New Database

To create a new database when you first launch the application, start changing the default data in the various forms. See “[Navigating Between Forms](#)” on page 6 for more information.

To begin a new database from an existing database, select File > Reset To Defaults.

To save the database, select File > Save.

## Programming a Radio

To program a radio:

1. Connect a radio to the PC. See “[Connecting a Radio to your PC](#)” on page 3 for more information.
2. Make sure the radio is connected to a power source and the power is on.
3. Switch the radio on.



**Tip:** Select Radio > Read, and then File > Save to backup the radio’s current data.

4. Make sure the correct radio model and data that you want to program is showing in the programming application.



**Caution:** Do not program the application’s default data into the radio.

5. Select the Radio > Program menu option, or select the Program button  from the toolbar.

As the programming database is programmed to the radio, the application indicates the radio model, and the software and database version numbers.

## Select a Different Radio Model

The radio model toolbar displays the various radio models available in the conventional programming application.

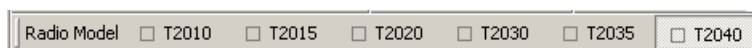

**Caution:** You cannot read a radio, change the radio model and then re-program the radio.

To select a specific radio model using a mouse, click on one of the buttons on the radio model toolbar.

To select a radio model using the keyboard:

1. Press Alt+R to select the Radio menu.
2. Press M to select the Model sub-menu option.
3. Use the cursor keys to highlight a radio model.
4. Press the Enter key.

Changing the model name will change the Radio Model field (Specifications form). This must be set correctly as not all programmable features are available for all radio models. Changing the value of the radio model will:

- make fields relevant to the new radio model selectable, where they were previously greyed out
- grey-out fields not relevant to the new radio model

If a radio model on the toolbar has a green indicator next to it, there is unsaved data for that radio model database. Select the radio model and File > [Save](#) if you want to keep changes made.

## Changing Access Levels

Access levels allow you to control access to various fields in the programming application. This can be useful when programming trunked radios, to prevent unwanted changes to critical network and fleet-related fields.

- To provide access to all fields, select Options > Access Level > High.
- Trunked radios only: to prevent access and changes to forms and fields in Network Settings, select Options > Access Level > Medium.
- Trunked radios only: to prevent access and changes to forms and fields in Network and Fleet settings (except Conventional Channels), select Options > Access Level > Low.
- To prevent access to everything except the radio language and power up message, select Options > Access Level > ID and Personalisation.



**Tip:** You can change the default access level when the application is first started by selecting Tools > Options.

## Navigating Between Forms

The forms tree on the left side of the main window lists the forms available.

To navigate:

- Keyboard: Scroll through the forms using the up and down arrow keys. Press the Enter key to open the form.
- Mouse: Left-click once on the name of a form to open it and begin changing data.

If a form has a green indicator next to it, there is unsaved data on that form. Select File > [Save](#) if you want to keep changes made.

# Application Menu Commands

---

The bar along the top of the main window shows the following menus:

- [File Menu](#)
- [Edit Menu](#)
- [Radio Menu](#)
- [Network Menu](#)
- [Tools Menu](#)
- [Help Menu](#)

These menus show various commands, some of which also appear as an icon on the toolbar.

To navigate the various menu commands:

**Keyboard:** Select a menu by pressing the Alt key, then the first letter of the menu's name. Use the up and down arrow keys to scroll through the list of commands, and press the Enter key to select a command. Select another menu using the left and right arrow keys. Press the Esc key to close a menu; the menu bar remains selected. Press the Esc key again to return to the main window.

**Mouse:** Select a menu by clicking on it, then clicking on the required command.

## File Menu

The commands available from the File menu are:



- [Reset To Defaults](#)
- [Open](#)
- [Import Network](#)
- [Revert to Saved](#)
- [Save](#)
- [Save As](#)
- [Printer Settings](#)
- [Print](#)
- [Exit](#)
- [Recent Files List](#)

**Reset To Defaults**     Selecting the File > Reset To Defaults command loads the application's default data for the current radio model.

- **Shortcut key:** Ctrl+D
- **Toolbar icon:** 

**Open**     Selecting the File > Open command opens an existing file.  
If a file was saved with comments, the comments will be displayed in the Comments window and the radio information will be displayed in the Radio Information window.

- **Shortcut key:** Ctrl+O
- **Toolbar icon:** 



Import Network	Selecting the File > Import Network command prompts for a file, from which the network will be imported. See <a href="#">“Importing a network” on page 69</a> for more information.
Revert to Saved	Selecting the File > Revert to Saved command returns to the last saved version of the current file.
Save	Selecting the File > Save command saves all data to the current file. If no file has been saved for the current data, the <a href="#">Save As</a> dialog will display, prompting for a file name and location. <ul style="list-style-type: none"> <li>■ Shortcut key: Ctrl+S</li> <li>■ Toolbar icon: </li> </ul>
Save As	Selecting the File > Save As command opens the Save As dialog, which prompts for a file name and location. Any comments you enter in the Comments window will be saved with the file, together with the information displayed in the Radio Information window.
Printer Settings	Selecting the File > Printer Settings command opens the Print Setup dialog in which you can select and configure the printer you wish to print to.
Print	Selecting the File > Print command opens the Print Selection window. You can then select one or more forms, and print data in those forms using the Print button. <ul style="list-style-type: none"> <li>■ Shortcut key: Ctrl+P</li> <li>■ Toolbar icon: </li> </ul>
Recent Files List	The list of recent files displays the names of files you have most recently opened in the application. To open a file, select File > [ <i>filename</i> ].
Exit	Selecting the File > Exit command exits the application.

## Edit Menu

The commands available from the Edit menu are:

- [Undo](#)
- [Cut](#)
- [Copy](#)
- [Paste](#)
- [Delete](#)
- [Select All](#)
- [Validate Form](#)
- [Revert Form](#)



Undo	Selecting the Edit > Undo command reverses the last command or deletes the last entry typed. This is greyed out if there is no action to undo. <ul style="list-style-type: none"> <li>■ Shortcut key: Ctrl+Z</li> </ul>
Cut	Selecting the Edit > Cut command places the text in a field on the clipboard, and deletes it from the field. This will be greyed out if there is no text to cut. <ul style="list-style-type: none"> <li>■ Shortcut key: Ctrl+X</li> </ul>

Copy	<p>Selecting the Edit &gt; Copy command places a copy of the selected grid data into the clipboard buffer. It will also copy the text in a field. This will be greyed out if there is no text to copy.</p> <ul style="list-style-type: none"> <li>■ Shortcut key: Ctrl+C</li> </ul>
Paste	<p>Selecting the Edit &gt; Paste command enters data into a grid from the clipboard. The data will be validated before it is entered. It will also paste text from the clipboard into a text field. This will be greyed out if there is no text to paste.</p> <ul style="list-style-type: none"> <li>■ Shortcut key: Ctrl+V</li> </ul>
Delete	<p>Selecting the Edit &gt; Delete command clears the currently selected data, or the next character in a text field.</p> <ul style="list-style-type: none"> <li>■ Shortcut key: Del</li> </ul>
Select All	<p>Selecting the Edit &gt; Select All command highlights all the text in the current field, or all the data in a grid.</p> <ul style="list-style-type: none"> <li>■ Shortcut key: Ctrl+A</li> </ul>
Validate Form	<p>Selecting the Edit &gt; Validate Form command checks the data in the current form for validity. This option will only appear if there are changes to validate, and will cause a green indicator to appear next to the form name in the forms tree. This indicates that there are changes to the form which need to be saved. Select File &gt; Save or Ctrl+S to save the database and reset all green indicators to their original state.</p> <p>Shortcut key: Ctrl+Y</p> <p>Toolbar icon: </p>
Revert Form	<p>Selecting the Edit &gt; Revert Form command discards any changes made to the current form.</p> <p>Shortcut key: Ctrl+T</p> <p>Toolbar icon: </p>

## Radio Menu

The commands available from the Radio menu are:

- [Read](#)
- [Program](#)
- [Interrogate](#)
- [Model](#)

Read	<p>Selecting the Radio &gt; Read command reads the radio's programming database and loads the relevant information into the application's forms.</p> <p>Shortcut key: Ctrl+R</p> <p>Toolbar icon: </p>
Program	<p>Selecting the Radio &gt; Program command programs the radio's programming database with the settings in the application's forms.</p> <p>Shortcut key: Ctrl+M</p> <p>Toolbar icon: </p>



Interrogate	<p>Selecting the Radio Interrogate command displays the radio model, software version and database version, without loading the database into the application.</p> <p>Shortcut key: Ctrl+I</p> <p>Toolbar icon: </p>
Model	<p>The Radio &gt; Model options switch between the various T2000 radio models. See <a href="#">“Select a Different Radio Model” on page 5</a> for more information. Options are:</p> <ul style="list-style-type: none"> <li>■ T2010</li> <li>■ T2015</li> <li>■ T2020</li> <li>■ T2030</li> <li>■ T2035</li> <li>■ T2040</li> </ul>

## Network Menu

The commands available from the Network menu are:

- [Add Network](#)
- [Delete Network](#)
- [Previous Network](#)
- [Next Network](#)

For more information, see [“Working with Multiple Networks” on page 68](#).

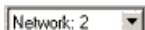
Add Network	<p>Selecting the Network &gt; Add command creates a new network database containing separate network, fleet and radio information.</p> <p>You can also add a network saved as a file on disk by selecting the File&gt;<a href="#">Import Network</a> command.</p> <p>Toolbar icon: </p>
Delete Network	<p>Selecting the Network &gt; Delete command deletes the currently selected network.</p> <p>Toolbar icon: </p>
Previous Network	<p>Selecting the Network &gt; Previous Network command switches to the previous network. This is only available if two networks have been defined, and you are currently on Network 2. See <a href="#">“Working with Multiple Networks” on page 68</a> for more information.</p> <p>Shortcut key: Ctrl+J</p> <p>Toolbar icon: </p>
Next Network	<p>Selecting the Network &gt; Next Network command switches to the next network. This is only available if two networks have been defined, and you are currently on Network 1. See <a href="#">“Working with Multiple Networks” on page 68</a> for more information.</p> <p>Shortcut key: Ctrl+K</p> <p>Toolbar icon: </p>



## Tools Menu

The commands available from the Tools menu are:



- [Access Level](#)
- [Options](#)

Access Level	Selecting one of the options under Tools > Access Level will restrict or add access to certain fields in the application. See <a href="#">“Changing Access Levels” on page 6</a> for more information.
Options	Selecting the Tools > Options command opens the Options window. The options are: <ul style="list-style-type: none"><li>■ <b>Communication Port:</b> The port used for communicating with radios</li><li>■ <b>Caption Position:</b> Select Left to align captions to the left, or Centre to place captions and checkboxes to the centre of each group box.</li><li>■ <b>Show General Dialogs:</b> Check this box to display general warnings, such as confirmations when starting or closing the application. Clear this box to hide these dialogs.</li><li>■ <b>Default Access Level:</b> Defines the access level when the application is started. See <a href="#">“Changing Access Levels” on page 6</a> for more information.</li><li>■ <b>Startup Position:</b> The state of the window when the application is started. Select Maximise to start the application window in a maximised state, Centre to start the application window reduced in the centre of the screen, or Previous to remember a custom window size when closing and restarting the application.</li><li>■ <b>Web Address:</b> The address used when the Help &gt; Internet &gt; Taitworld command is selected.</li></ul>

## Help Menu

The commands available from the Help menu are:

- [Contents and Index](#)
- [What’s This?](#)
- [Internet](#)
- [About](#)

Contents and Index	Selecting the Help > Contents and Index command launches <a href="#">Online Help</a> for the application, open at the Contents tab. Shortcut Key: F1 Toolbar Icon: 
What’s This?	Selecting the Help > What’s This? command changes the cursor to an arrow with a question mark, and enables you to click on a field to get popup help for that field. See <a href="#">“What’s This? Help” on page 19</a> for more information. Shortcut Key: Shift+F1 Toolbar Icon: 

- Internet                      Selecting the Internet > Mobiles Support command launches your default browser and loads the address specified in the Website Address field (Tools > Options). Selecting the Internet > Taitworld command launches the Tait home page (<http://www.taitworld.com>).
- About                              Selecting the Help > About command displays information about the application.

# Changing Data

---

If a field's data is greyed out, then that data is displayed for information only and cannot be changed. If a field name is greyed out, then that option is not available for the radio being programmed. For information on how to enable a field that is greyed out, select [What's This? Help](#) , then click on the field label you want information on.

Where a range of possible numeric values is available for a field, then that range is shown in the bottom left corner of the form.



Min: 10    Max: 60    Step: 10    Unit: seconds

How you change and add data for each field depends on how that data is displayed. There are four options:

- [Text Box](#)
- [Combo Box](#)
- [Check Box](#)
- [Grids](#)

## Text Box

A text box is used for numeric and alphanumeric data.

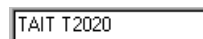

TAIT T2020

To change data in a text box:

- Keyboard: Select a text box using the Tab key. Enter the required data.
- Mouse: Select a text box by clicking on it with the mouse. Enter the required data.

## Combo Box

A combo box is used for fields that have a range of possible values and appears as a box with an arrow at the right side.

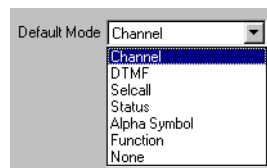

Default Mode: Channel

- Channel
- DTMF
- Selcall
- Status
- Alpha Symbol
- Function
- None

To change data in a combo box:

- Keyboard: Select a combo box using the Tab key. You can then display the options available by pressing the Alt key and the down arrow key at the same time. Use the up and down arrow keys to scroll through the options until the required value is displayed, then press the Enter key. You can also press a letter to cycle through entries starting with that letter.
- Mouse: Select a combo box by clicking on it, which displays the list of values. Select the required value from the combo box.

## Check Box

A check box is used for fields that are either enabled or disabled. If the box is checked, the field is enabled; if the box is blank, the field is disabled.

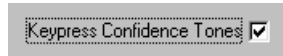

To change data in a check box:

**Keyboard:** Select a check box using the Tab key. Use the space bar to enable and disable the field.

**Mouse:** Select a check box and change its value by clicking on it with the mouse.

## Grids

A grid is used where many lines of data are required, each containing the same type of information. The data in a grid is displayed in text boxes and combo boxes. Combo boxes in a grid appear to be text boxes until they are selected, when an arrow appears on the right side.



**Tip:** You can sort information in a grid by clicking on the various column headers.

Forms that contain grids also contain additional buttons:

- **Add:** Adds a new row for data entry.
- **Insert (Channels form):** Inserts a new row using the next available ID.
- **Repeat:** Duplicates the data from the selected row, giving it a new name.
- **Delete:** Removes the currently selected row of data.

To change data within a grid:

- **Keyboard:** Select the different fields in a grid using the Tab key or the right and left arrow keys. Pressing the up or down arrow keys moves up or down a row of data. Start typing in a cell to replace the existing data, or press F2 to edit a cell's contents without deleting existing data.
- **Mouse:** Single click on the required field and begin typing to replace existing data. Click twice on the required field to edit a cell's contents without replacing the existing data.

# Transferring Data

You can copy and paste or drag and drop single cells or rows to a grid from a Microsoft® Excel spreadsheet. You can also copy fields or groups of fields between radio models.

## Copying Data Into Grids From Excel

You can enter data into a Microsoft® Excel spreadsheet, and then copy or drag and drop that data into a grid. This can be useful when there are a large number of records to configure, such as the 1200 channel functionality of conventional T2020 radios with firmware version 7.01 or higher.

To copy data into a grid from Excel:

1. In Excel, type the information exactly as it will appear in the grid.

For the Channels form, columns such as “ID”, “Channel”, “RX Frequency” should appear as a unique cell, sharing the same row.

For each column under the header name, enter data that you want to import.

	A	B	C	D	E	F	G	H	I	J
3										
4	ID	Channel	RX Frequency	TX Frequency	Rx Sig	Tx Sig	Tx Call	Repeater	Power	Bandwidth
5	1	chan1	126.45	130	c67.0	c77.0		1 None	low	wide
6	2	chan1	126.45	130	c67.0	c77.0		1 None	low	wide

2. In Excel, select the block of data you have entered, either using Shift and the cursor keys on the keyboard or left click and drag using the mouse.
3. Select Edit > Copy to copy the information to the clipboard.
4. Open the T2000 Conventional Programming Application, and navigate to the grid where you want to paste the data (for example, the Channels form).
5. Click on a cell in the grid to bring focus to the grid.
6. Select Edit > Paste.

If the information on the clipboard is valid it will appear in the grid, replacing any current data.

The T2000 programming application also supports drag and drop from Microsoft® Excel to the various grids.

## Copying Fields

### To copy a field to another radio model:

1. Right click on the field or field label that you want to copy.

The cursor will change to an arrow with a plus sign, and the status bar will display the text “copy the *[Field]* setting ...”

2. While still holding the right mouse button, drag the field to another radio model on the radio model toolbar.

The status bar will display the text “copy the *[Field]* setting to the *[radio model]* radio model”.

3. Release the left mouse button.

If the copy was successful and general dialogs are enabled (Tools > Options), an information box will state “*[Field]* successfully copied to *[radio model]*”.

**To copy a group of fields to another radio model:**

1. Right click on the group box or box label that contains the fields that you want to copy.

The status bar will display the text “copy the *[Label]* details ...”

2. While still holding the right mouse button, drag the group box to another radio model on the radio model toolbar.

The cursor will change to an arrow with a plus sign and the status bar will display the text “copy the *[Label]* details to the *[radio model]* radio model”.

3. Release the left mouse button.

If the copy was successful and general dialogs are enabled (Tools > [Options](#)), one or more information boxes will state “*[Field]* successfully copied to *[radio model]*”.

# Part B Getting and Using Help

This part describes how to get and use help in the T2000 Programming Application.

## Topics

- [Online Help](#)
- [What's This? Help](#)
- [Help on the Internet](#)





# Getting and Using Help

---

There are 3 ways of getting help in the T2000 Programming Application:

- [Online Help](#)
- [What's This? Help](#)
- [Help on the Internet](#)

## Online Help

Press F1 or select Help > Contents and Index.

The series of buttons along the top of the help window include:

- Hide/Show: Select the Hide or Show button to display or hide the left most pane of the Help window, containing Contents, Search and Favorites.
- Back: Select the Back button to go back to the topic you last viewed.
- Print: Select the Print button to print either the current topic or the current topic and subtopics.
- Options: Select the Options button to change Internet Options, print topics and turn the Search Highlight on or off.
- Click blue underlined text to jump to another topic.

### *Useful Help File Features*

In the help file you can:

- Search topics: From the Search tab, enter one or more keywords and select the List Topics button. Highlight a topic from the list and select the Display button to show the topic in the pane to the right.
- Save topics as a Favorite: With a topic displayed, select the Favorites tab. If you want to reference the topic by a different name, you can enter another title in the Current topic box. Select the Add button to save the topic in the Topics list for future reference.

## What's This? Help

1. Press Shift+F1 or Select Help > What's This?.

The cursor will change to an arrow with a question mark.

2. Move the cursor to the field you want help on.
3. Left click once on the field or the field label.

A popup definition of the field will appear.

4. Left click again anywhere on the screen to make the popup disappear.

Click blue underlined text to jump to the relevant information in the [Online Help](#) file.

## Help on the Internet

Select Help >Internet >Mobiles Support.

The mobiles section of the support website allows you to access support material such as operator's manuals and user guides. If you have password access, you can also search through Technical Support documentation, and gain access to product updates.



# Part C Programming Conventional Features

This part contains detailed information on programming T2010, T2015 and T2020 radios.

## Topics

- [What's New - T2000 Conventional Radios](#)
- [Basic Radio Settings](#)
- [Setting Up Signalling Options](#)
- [Setting Up Channels and Scan Groups](#)
- [Special Features](#)
- [Radio Interface Options](#)



# What's New - T2000 Conventional Radios

---

Key:

- N/A = Not Applicable.
- \* = not a full release.

Feature	Form	Radio Firmware Version		Database Version
		T2010/T2015	T2020	
Reverse Tone Burst Duration	Subaudible Signalling	N/A	5.24	2.07
Fast PTT Via AUX Line	Transmitter Setup	3.05	N/A	2.01
Tx Call	Channels	3.05	N/A	2.01
BCD Polarity Inverted	Channels	3.02*	N/A	2.01
BCD Channel Selection	Channels	3.01*	N/A	2.01

# Basic Radio Settings

This section contains detailed information on changing basic radio settings.

## Specifications (Conventional) Form

The Specifications form shows basic radio information such as the radio model and the frequency band. You can also set various radio interface options in this form, such as the power-up message, and specify installed hardware options.

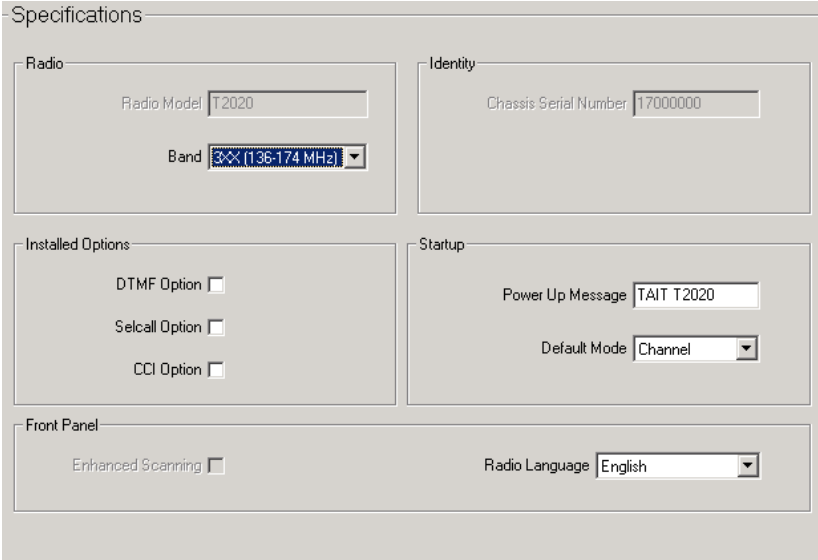

The screenshot shows a 'Specifications' form with the following fields and options:

- Radio:** Radio Model (T2020), Band (136-174 MHz)
- Identity:** Chassis Serial Number (17000000)
- Installed Options:** DTMF Option, Selcall Option, CCI Option (all unchecked)
- Startup:** Power Up Message (TAIT T2020), Default Mode (Channel)
- Front Panel:** Enhanced Scanning (unchecked), Radio Language (English)

You may wish to read data from a radio of a different type and use the settings as a template for programming radios of another variant. If so, change the values of radio model and/or radio band after loading the template file but before changing any other radio settings.

### Radio Model

The Radio Model field indicates the radio's feature set, which is indicated by the fourth and fifth positions of the radio part number.

**T2010-343**  
|  
radio model

10 indicates the **T2010** feature set, 15 indicates the **T2015** feature set and 20 indicates the **T2020** feature set.

The Radio Model field is set using the radio model toolbar (see [“Select a Different Radio Model” on page 5](#)). This must be set correctly as not all programmable features are available for all radio models. Changing the value of the radio model will:

- make fields relevant to the new radio model selectable, where they were previously greyed out
- grey-out fields not relevant to the new radio model

## Radio Band

The Radio Band field sets the frequency band in which the radio operates, and is indicated by the sixth position (first after the hyphen) in the radio part number.

**T2010-343**

↑  
frequency band

This number indicates the frequency band as follows:

Band	Frequency Range	Band	Frequency Range
0	500-530 MHz	5	400-470 MHz
1	220-270 MHz	6	450-520 MHz
2	66-88 MHz	7	330-366 MHz
3	136-174 MHz	8	800-870 MHz
4	175-225 MHz	9	360-400 MHz



**Note:** Contact your local dealer for information on the availability of different frequency bands.

The Radio Band field must be set correctly in order to validate channel settings, and changing the value of the radio band will set the values of the [Rx and Tx Frequencies](#) field (Channels form) to 0, as any frequency values previously entered may be invalid for the new radio band.

## DTMF Option

T2020 radios only.

The DTMF Option field is checked if dual tone multiple frequency (DTMF) hardware is installed in the radio. Settings for this option are made in the DTMF form.

## Selcall Option

Select this option if signalling hardware is installed in the radio that allows Selcall multi-tone (Selcall) signalling to be used. Once this option is selected, the Selcall forms will become available in the forms tree. The number of Selcall forms available depend on the radio model.

The checkbox will be greyed out if there is no signalling hardware installed in the radio.

## CCI Option

T2020 radios only.

The CCI field is checked if computer controlled interface (CCI) hardware has been installed in the radio. CCI hardware is for data communication, which is configured in the CCI form.

## Enhanced Scanning

T2015 radios only.

The Enhanced Scanning Field enables or disables enhanced scanning for T2015 radios. Selecting this field will enable the [Enhanced Scan Form](#) and will enable priority scanning (primary and secondary) in the [Channels Form](#) > [Scan](#) field.

## Chassis Serial Number

The Chassis Serial Number is automatically read from the radio's memory and is used for identification only. The chassis serial number has no effect on the normal operation of the radio.

Power Up Message

T2020 radios only.

The Power Up Message field sets the power-up message, which can be up to 24 characters. Choose from: A to Z 0 to 9 \* + - < > / \ space

Enter up to 12 characters, including leading spaces if you want the message to be centred.

Default Mode

T2020 radios only.

The Default Mode field sets the mode the radio reverts to at power-up and after 10 seconds of no user activity. If default mode is set to None, the radio powers up in the mode selected when the radio was last on.

The modes available are outlined below:

Table 1: Default modes available for T2020 radios

Option	Description
Channel	Channel Entry/Selection Mode. In channel entry mode, or channel selection mode, the user can change to a different channel or scan group.
DTMF	DTMF Dialling Mode. In DTMF dialling mode, the user can dial DTMF strings. DTMF dialling mode is available when the Manual Dialling field in the DTMF form is enabled.
Selcall	Selcall Dialling Mode. Using Selcall dialling, the user can dial Selcall sequences using the keypad.
Status	Status Entry Mode. In status entry mode, the radio user can change the status to reflect their current activity. The corresponding status digit is sent with Selcall sequences that include variable status (V).
Alpha Symbol	Alphanumeric Entry Mode. In alphanumeric entry mode, the user can select and execute up to 20 alpha symbols.
Functions	User Function Menu Entry Mode. In user function menu entry mode, the user can customise radio options.
None	No Default Mode. When no default mode has been programmed, the radio powers up in the mode selected when the radio was last on.

Radio Language

T2020 radios only

The Radio Language field sets the language of messages that appear on the radio LCD. Select French, German, or English.

## Receiver Monitoring Form

The fields in the Receiver Monitoring form set properties related to the operation of the radio's monitor function.



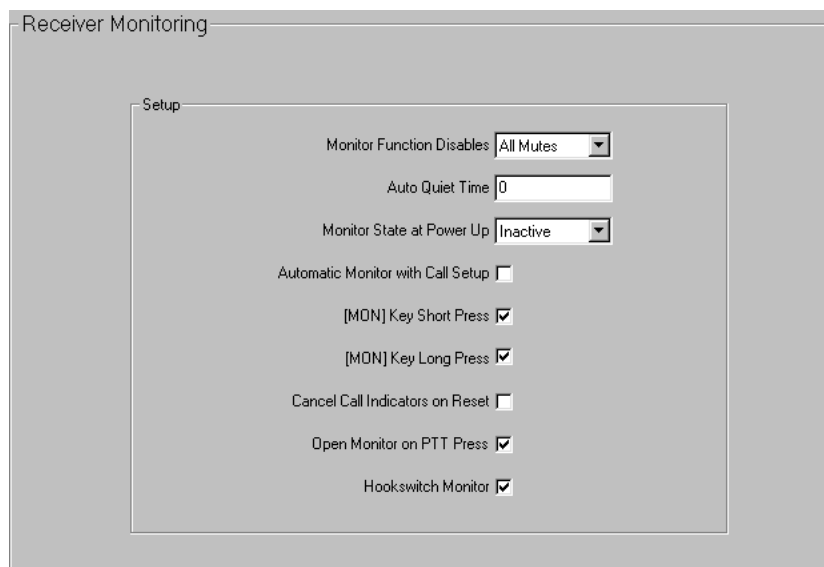

Monitor Function Disables	<p>The Monitor Function Disables field determines which mutes are to be disabled by the monitor function.</p> <ul style="list-style-type: none"> <li>■ None (T2010 only): When the monitor function becomes active, no mutes are disabled.</li> <li>■ All Mutes: Both the selective call mute and the subaudible signalling mute (CTCSS and DCS) are overridden when monitor is activated. The radio user is able to hear all traffic.</li> <li>■ Selcall Mute: Only the Selcall mute is overridden when monitor is activated. The radio user only hears traffic that has subaudible signalling.</li> </ul>
Auto Quiet Time	<p>The Auto Quiet Time field sets the duration of the auto quiet timer. When the programmed duration of the auto quiet timer expires, monitor deactivates and the radio resumes normal operation. Enter a value between 1 and 250 seconds (T2010 and T2015 radios) or 255 seconds (T2020 radios) in steps of 1 second, or 0 to disable the auto quiet timer.</p>
Monitor State at Power Up	<p>T2020 radios only.</p> <p>The Monitor State at Power Up field determines whether monitor is inactive or active when the radio is turned on.</p>
Automatic Monitor with Call Setup	<p>T2020 radios only.</p> <p>The Automatic Monitor with Call Setup field determines whether monitor is activated when an outgoing Selcall call is made. For this field to be available, Selcall hardware must be installed in the radio.</p> <ul style="list-style-type: none"> <li>■ Checked: Monitor is activated when a Selcall call is successfully sent.</li> <li>■ Unchecked: The radio can transmit Selcall calls without activating monitor. Monitor must be activated via another method before communication commences.</li> </ul>
[MON] Key Short Press	<p>The [MON] Key Short Press field sets the behaviour of the radio when the monitor key is given a short press.</p>

When the [MON] Key Short Press field is checked, a short press of the monitor key toggles monitor on and off. If unchecked, a short press of the monitor key only disables monitor.

[MON] Key Long Press

The [MON] Key Long Press field sets the behaviour of the radio when the monitor key is given a long press.

When the [MON] Key Long Press field is checked, a long press of the monitor key activates the squelch override function. This can be useful where there is activity in marginal areas and the signal is too weak to be reliably heard.

If squelch override is already active when the monitor key is pressed, then squelch override is deactivated and monitor is activated.

Cancel Call Indicators on Request

T2020 radios only.

When the Cancel Call Indicators on Request field is checked, the ringing tone and the call indicator light will be cancelled if a radio monitor reset is received. This option is only available if Selcall is fitted.

Open Monitor on PTT Press

T2020 radios only.

When the Open Monitor on PTT Press field is checked, the audio monitor opens when the PTT key is pressed.

Hookswitch Monitor

When the Hookswitch Monitor field is checked, the monitor is activated when the hookswitch is open. Setting this option does not affect any other scanning functions of the hookswitch.

## Transmitter Setup Form

Transmitter options are set in the Transmitter Setup form.

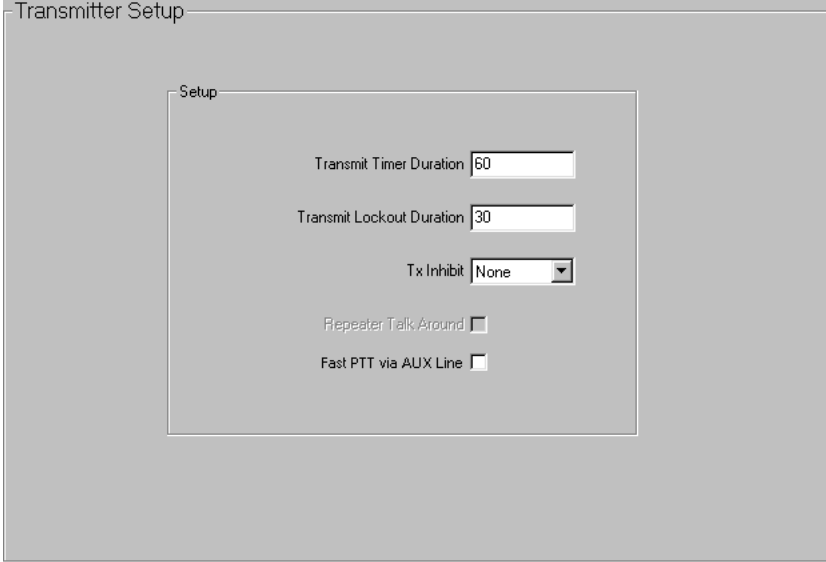

The screenshot shows a window titled "Transmitter Setup" with a "Setup" sub-window. Inside the "Setup" window, there are five fields:

- Transmit Timer Duration: 60
- Transmit Lockout Duration: 30
- Tx Inhibit: None (dropdown menu)
- Repeater Talk Around:
- Fast PTT via AUX Line:

Transmit Timer Duration

The Transmit Timer Duration field sets the duration of the transmit timer, which determines the longest continuous transmission permitted by the radio. Enter a value between 1 and 250 seconds in steps of 1 second, or 0 to disable the transmit timer. The recommended value is 60 seconds.



**Caution:** *It is recommended that you do not disable the transmit timer, as frequent lengthy transmissions, whether intentional or accidental, could damage the radio's transmitter and can be a nuisance to others.*

Once the transmit timer expires, the radio may be prevented from transmitting for the duration of the transmit lockout timer, which is set in the [Transmit Lockout Duration](#) field.

Transmit Lockout Duration	The Transmit Lockout Duration field sets the duration of the transmit lockout timer. Enter a value between 1 and 250 seconds in steps of 1 second, or 0 to disable the transmit lockout timer. The recommended value is 30 seconds.
Tx Inhibit	<p>The Tx Inhibit field sets the transmit inhibit conditions (None, Busy or Mute).</p> <ul style="list-style-type: none"><li>■ None: The radio transmits when the PTT is pressed, even when there is traffic on the channel.</li><li>■ Busy: The radio does not transmit when the PTT is pressed if there is activity on the channel, whether it is valid or invalid.</li><li>■ Mute: The radio does not transmit when the PTT is pressed if there is activity on the channel and the mute is active. This could be caused by an invalid CTCSS/DCS code or an active Selcall mute. If monitor has been activated, the radio transmits regardless of valid or invalid activity.</li></ul> <p>A Selcall call initiation (via the press of the auxiliary key, call key or a function key) follows the conditions set in Tx Inhibit.</p>
Repeater Talk Around	<p>T2020 radios only.</p> <p>When the Repeater Talk Around field is checked, a long press of the channel key activates repeater talkaround. Repeater talkaround allows the radio user to bypass repeater operation and so communicate directly with other radios. While repeater talkaround is active, all transmissions are made on the receive frequency programmed for the channel.</p>
Fast PTT via AUX Line	<p>T2010/T2015 radios only.</p> <p>When the Fast PTT via AUX Line field is checked, and the PTT is wired to the AUX line on the options connector, the AUX output line is used as the PTT input line. This results in more frequent polling, and faster PTT for data applications.</p>

# Setting Up Signalling Options

This section contains detailed information on setting up subaudible and Selcall signalling.

## Subaudible Signalling Form

The Subaudible Signalling form is divided into two tabs. For T2010/T2015 radios, only Signalling is available.

- [Signalling](#) tab
- [Presets](#) tab

### Signalling Tab

Settings for CTCSS and DCS transmissions are determined in the Signalling tab. CTCSS and DCS for individual channels are set in the [CTCSS/DCS Rx/Tx](#) fields (Channels form).

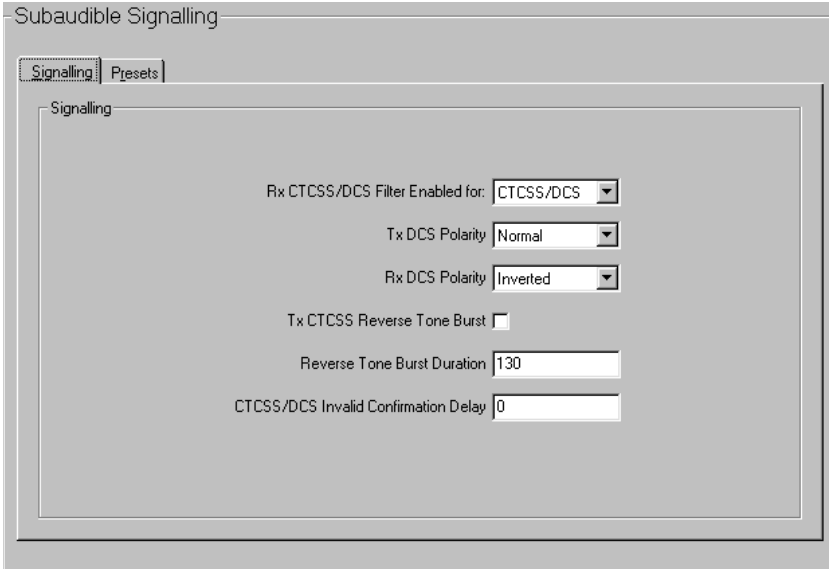

The screenshot shows the 'Subaudible Signalling' window with the 'Signalling' tab selected. The 'Presets' tab is also visible. The 'Signalling' section contains the following fields:

- Rx CTCSS/DCS Filter Enabled for:
- Tx DCS Polarity:
- Rx DCS Polarity:
- Tx CTCSS Reverse Tone Burst:
- Reverse Tone Burst Duration:
- CTCSS/DCS Invalid Confirmation Delay:

Rx CTCSS/DCS Filter Enabled For

The Rx CTCSS/DCS Filter Enabled For field determines the settings for the radio's CTCSS/DCS filter. The filter can be automatically switched off for channels that do not have CTCSS or DCS.

- All: The filter is active on all channels, regardless of whether they are programmed with CTCSS or DCS.
- CTCSS/DCS: The filter is active only on channels that have CTCSS or DCS programmed for the receive frequency.

Tx DCS Polarity

The Tx DCS Polarity field sets the polarity of all transmitted DCS codes defined in the [Tx Sig](#) field (Channels form). Some systems require the DCS code to be inverted when transmitted. Select Normal or Inverted.

Rx DCS Polarity

The Rx DCS Polarity field sets the polarity of all received DCS codes defined in the [Rx Sig](#) field (Channels form). Select Normal or Inverted.

Tx CTCSS Reverse Tone Burst

When the Tx CTCSS Reverse Tone Burst field is checked, a reverse tone burst on the end of a CTCSS transmission speeds up the shut down of CTCSS decodes, providing your decoder is capable of detecting a reverse tone burst. When this field is unchecked, no reverse tone burst is transmitted.

Reverse Tone Burst Duration

T2020 radios only.

The Reverse Tone Burst Duration field specifies how long a CTCSS reverse tone burst is transmitted. Reverse tone burst transmission increases the speed of receiver shutdown in some repeaters and associated equipment.

Set a value from 0 to 250 ms in steps of 1 ms. Setting this field to 0 disables reverse tone burst transmission.

The recommended value is 130 ms, which works for all CTCSS tones between 67.0 and 250.3 Hz. Longer durations may be used for lower CTCSS frequencies and shorter durations for higher CTCSS frequencies. However, it should not be necessary to deviate from 130 ms unless your system has specific requirements.

## Presets Tab

T2020 radios only.

In the Subaudible Signalling Presets tab, user selectable signalling pairs are defined. The radio user selects the preset from the radio control head and the selected frequency pair overrides the programmed subaudible signalling frequency for the current channel, as set in the [Rx/Tx Sig](#) fields (Channels form). A maximum of 20 signalling presets can be set.

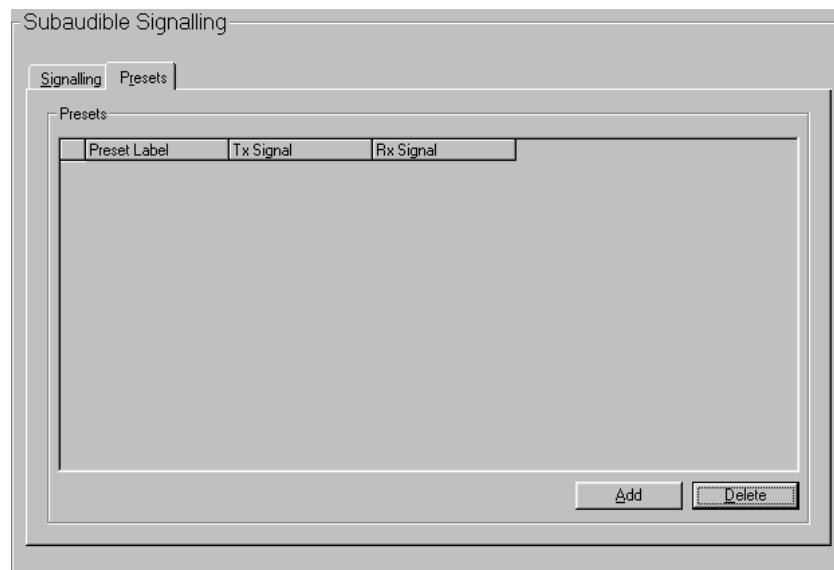

Preset Label

The Preset Label field defines an identification label for each preset. This label is displayed on the radio control head during the channel signalling programming session.

Enter a label of up to 8 characters, chosen from A to Z 0 to 9 \* + - < > / \ space.

A default label is generated, starting with PRESET0, and this can then be edited. Do not allocate the same label for different presets.

## Rx/Tx Signals

The Tx Signal field sets the frequency of the subaudible signal that accompanies each transmission made on the channel. The Rx Signal field sets the subaudible signal frequency that the radio must receive before the activity is regarded as valid and the mute opened.

For both fields, select the required CTCSS frequency or DCS code from the drop-down list.

## Selcall Identity Form

Selcall systems are set up in the Selcall Identity form, which is divided into three tabs:

- [Selcall Identity](#) tab
- [Selcall Setup](#) tab
- [Selcall Sequences](#) tab

### Selcall Identity Tab

The transmit and receive tone sequence formats are defined in the Selcall Identity tab, together with sequences the radio responds to.

The screenshot shows the 'Selcall Identity' form with three tabs: 'Selcall Identity', 'Selcall Setup', and 'Selcall Sequences'. The 'Selcall Identity' tab is active. It contains several input fields and checkboxes:

- Selcall Sequences Format:**
  - Tx Format:
  - Rx Format:
  - Auto Ack Format:
- Radio Monitor Reset:**
  - RMR Sequence:
  - RMR Acknowledge:
- Radio Unit Identity Sequences:**
  - Rx Decode Sequence 1:
  - Rx Decode Sequence 2:
- Transmission Sequences:**
  - A.N.I. Sequence:
  - ANI Beep:
  - Auto Acknowledge:
  - Auto Ack Beep:
  - Caller Identification:
  - Emergency Sequence:

## Tx Format

Define the transmit (Tx) format, using the characters B, R, C, - (gap) and S. The transmit format consists of up to seven bursts of these characters, where a burst is made up of a group of the same character e.g. RRR (a three digit receiver identity).

The five characters used to define the transmit format are:

- B (repeater identity). Optional. This is only defined once in the sequence and is positioned at the beginning of the sequence. For T2010/T2015 radios, the B burst must have a minimum of 2 digits.
- R (receiver identity). Required. This is only defined once in the sequence. For T2010/T2015 radios, the R burst must have a minimum of 2 digits.
- C (caller identity). Optional. This is only defined once in the sequence. For T2010/T2015 radios, the C burst must have a minimum of 2 digits.
- - (gap). Optional. A gap burst can occur more than once in a sequence, but the sequence cannot start or end with a gap burst. Do not place more than eight characters in a row without a gap burst.

	<ul style="list-style-type: none"> <li>■ S (status). Optional. This is only defined once in the sequence and is positioned at the end, separated from the other characters by a - (gap). The status burst has a maximum length of two digits.</li> </ul>
Rx Format	<p>Define the receive (Rx) format, using the characters R, C, - (gap) and S. The receive format consists of up to five bursts of these characters, where a burst is made up of a group of the same character e.g. RRRRRRRR (an eight digit receiver identity).</p> <p>The four characters used to define the receive format are:</p> <ul style="list-style-type: none"> <li>■ R (receiver identity). Required. This is only defined once in the sequence. For T2010/T2015 radios, the R burst must have a minimum of 2 digits.</li> <li>■ C (caller identity). Optional. This is only defined once in the sequence. The total length of the C burst is less than or equal to the length of the R burst in the transmit format. For T2010/T2015 radios, the C burst must have a minimum of 2 digits.</li> <li>■ - (gap). Optional. A gap burst can occur more than once in a sequence but the sequence cannot start or end with a gap burst. Do not place more than eight characters in a row without a gap burst.</li> <li>■ S (status). Optional. This is only defined once in the sequence and is positioned at the end, separated from the other characters by a - (gap). The length of the status burst in the Rx format must be the same as the status burst in the <a href="#">Tx Format</a>.</li> </ul>
Auto Ack Format	<p>Define the auto ack (<a href="#">Auto Acknowledge</a>) format using the characters B, A, C, - (gap) and S. The auto acknowledge format consists of up to seven bursts of characters, where a burst is made up of a group of the same character e.g. AAAAA (a five digit auto acknowledge identity).</p> <p>The five characters used to define the auto acknowledge format are:</p> <ul style="list-style-type: none"> <li>■ B (repeater identity). Optional. This is only defined once in the sequence and is positioned at the beginning of the sequence. For T2010/T2015 radios, the B burst must have a minimum of 2 digits.</li> <li>■ A (auto acknowledge identity). Required. This is only defined once in the sequence. For T2010/T2015 radios, the A burst must have a minimum of 2 digits.</li> <li>■ C (caller identity). Optional. This is only defined once in the sequence. The total length of the C burst is less than or equal to the length of the C burst in the <a href="#">Tx Format</a>. For T2010/T2015 radios, the C burst must have a minimum of 2 digits.</li> <li>■ - (gap). Optional. A gap burst can occur more than once in a sequence, but the sequence cannot start or end with a gap burst. Do not place more than eight characters in a row without a gap burst.</li> <li>■ S (status). Optional. This is only defined once in the sequence and is positioned at the end, separated from the other characters by a - (gap). The length of the status burst in the auto acknowledge format must be the same as the status burst in the Tx Format.</li> </ul>
Radio Monitor Reset (RMR) Sequence	<p>The Radio Monitor Reset Sequence field sets the Selcall sequence that, when received, deactivates monitor and squelch override. If the <a href="#">Cancel Call Indicators on Request</a> field (Receiver Monitoring form) has been checked, then the ringing tone and call indicator light is cancelled on receipt of a radio monitor reset sequence.</p>

The sequence entered must match the R burst (receiver identity) in the Selcall system's [Rx Format](#). Use characters 0 to 9, B, C, D or F. On T2020 radios a \* wild card tone can also be used, representing any other tone.

If the [Emergency Sequence](#) is defined, then the Radio Monitor Reset Sequence must also be defined.

Radio Monitor Reset (RMR) Acknowledge

T2020 radios only.

When the Radio Monitor Reset Acknowledge field is checked, an auto acknowledge is sent when a valid radio monitor reset sequence is received.

An auto acknowledge sequence must be defined in the [Auto Acknowledge](#) field for an auto acknowledge to be sent.

Rx Decode Sequences

The Rx Decode 1 and Rx Decode 2 sequences can be defined for each Selcall system the radio operates on. At least one of the Rx Decode fields must be set, and the sequence entered must match the R burst (receiver identity) in the Selcall system's [Rx Format](#) field. On T2010/T2015 radios, only one Rx decode sequence can be set.

Use characters 0 to 9, B, C, D or F to define each sequence. On T2020 radios a \* wild card tone can also be used, representing any other tone. If the second Rx decode sequence is not required, leave it set to 00000.

ANI Sequence

The ANI sequence field defines the ANI sequence transmitted whenever the PTT is pressed, according to the ANI encoding properties set in the [Selcall Setup](#) tab. The length of the ANI sequence entered must match the length of the R burst (receiver identity) in the [Tx Format](#) field.

Use characters 0 to 9, B, C, D, F or G. The G represents a group tone, which identifies incoming Selcall sequences as group calls.

If status is required, it must come last in the sequence and is separated from the Selcall address by a - (gap). If there is one status digit in the Tx Format then the values 0 to 15 can be used. If there are two status digits used in the Tx Format, then the values 0 to 99 can be entered. If variable status is required (T2020 only), then enter V instead of the status number.



**Note:** In all instances, the ANI sequence is only transmitted if the ANI suppression time has expired.

At least one of [Leading ANI](#), [Random ANI](#) and [Trailing ANI](#) must be enabled if ANI transmission is to be valid. If no ANI sequence is required either check the [ANI Beep](#) field or leave the ANI sequence field blank.

ANI Beep

When the ANI Beep field is checked, the ANI sequence is in the form of a single beep, which is tone 6 of the Selcall system's tone set, transmitted for 500 ms. When this field is checked, the [ANI Sequence](#) field is unavailable.

Auto Acknowledge

The Auto Acknowledge Sequence field defines the auto acknowledge sequence transmitted whenever the radio has decoded a valid Selcall sequence and an auto acknowledge is required. The format of the auto acknowledge sequence entered in this field must match the format defined in the [Auto Ack Format](#) field.

Use characters 0 to 9, B, C, D, F or G. The G represents a group tone, which identifies incoming Selcall sequences as group calls.



If status is required, it must come last in the sequence and is separated from the Selcall address by a - (gap). If there is one status digit in the Auto Ack Format then the values 0 to 15 can be used. If there are two status digits used in the Auto Ack Format, then the values 0 to 99 can be entered. If variable status is required (T2020 only), then enter V instead of the status number.



**Note:** in all instances, the auto acknowledge sequence is only transmitted if the [Auto Acknowledge Delay](#) has expired.

#### Auto Acknowledge Beep

When the Auto Acknowledge Beep field is checked, the auto acknowledge sequence is in the form of a single beep, which is tone 6 of the Selcall system's tone set, transmitted for 500 ms. When this field is checked, the [Auto Acknowledge](#) field is unavailable.

#### Caller Identification Sequence

The Caller Identification Sequence field defines the identity of the radio transmitting the Selcall sequence. The length of this sequence matches the length of the C burst (caller identity) in the [Tx Format](#). Use characters 0 to 9, B, C, D or F to define the caller identification sequence.

#### Emergency Sequence

The sequence defined in the Emergency Sequence field is the Selcall sequence that is transmitted when an emergency call is made. The sequence entered in this field mirrors the sequence defined in the [Selcall Emergency](#) form (T2020 only). If the sequence is modified in one form, the sequence appearing in the other is automatically updated.

The length of the emergency sequence matches the length of the R burst (receiver identity) in the [Tx Format](#). Use characters 0 to 9, B, C, D, F or G to define the emergency Selcall sequence. If status is required, it must come last in the sequence and is separated from the Selcall address by a - (gap). If there is one status digit in the Tx Format then the values 0 to 15 can be used. If there are two status digits used in the Tx Format, then the values 0 to 99 can be entered. If variable status is required (T2020 only), then enter V instead of the status number.

For T2010/T2015 radios, the emergency sequence will transmit on the current channel.

## Selcall Setup Tab

Basic Selcall characteristics are set in the Selcall Setup tab.

- Tone Set** The Tone Set field specifies the tone set a Selcall system operates on. The radio can operate with any of the tone sets supported by the radio software. The available tone sets are: [CCIR](#), [EIA](#), [EEA](#), [ZVEI-I](#), [ZVEI-II](#), [ZVEI-III](#), [PZVEI](#), [NATEL](#) and [DZVEI](#). The available tone sets are described in [Table 2 on page 37](#).
- Tone Period** The Tone Period field sets the duration of each tone in a Selcall sequence. Set the tone period to 20, 33, 40, 50, 60, 70 or 100 ms. Note that 20 is not selectable if the EIA tone set has been chosen in the [Tone Set](#) field.
- Lead In Tone** The Lead In Tone field sets the tone which is sent during the lead in delay, before any Selcall sequences. It can be used to halt scanning on a called radio before critical tones are sent or to allow the called radio time to come out of economy mode. Set this tone to any of the valid tones in the current tone set (0-9, A-F) or None. If the Lead In Tone field is set to None, then the radio transmits for the [Lead In Delay](#) time without sending any tone.
- If a lead in tone is set to a value other than None, the lead in tone is transmitted for the duration of the lead in delay for all outgoing Selcall sequences except for random and trailing ANI.
- Lead In Delay** The Lead In Delay field sets the duration of the [Lead In Tone](#) before all Selcall sequence transmissions, except random and trailing ANI. Set this field to between 0 and 5,000 ms in steps of 20 ms.
- If Selcall is being used with scanning, then the lead in delay should be set to a value equivalent to the time it takes for a scan group to do one complete scan of all channels.
- If Selcall is being used on a repeater system, add an additional 200 ms to the lead-in delay.
- Leading ANI** When the Leading ANI field is checked, the ANI sequence is sent whenever the PTT is pressed, after the specified [Lead In Delay](#) time has expired.
- A valid ANI sequence must be defined in the [ANI Sequence](#) field.

Table 2: Selcall tone sets and frequencies (Hz). Note: E is the repeat tone.

Tone	CCIR	EIA	EEA	ZVEI-I	ZVEI-II	ZVEI-III	PZVEI	NATEL	DZVEI
0	1981	600	1981	2400	2400	2400	2400	1633	2200
1	1124	741	1124	1060	1060	1060	1060	631	970
2	1197	882	1197	1160	1160	1160	1160	697	1060
3	1275	1023	1275	1270	1270	1270	1270	770	1160
4	1358	1164	1358	1400	1400	1400	1400	852	1270
5	1446	1305	1446	1530	1530	1530	1530	941	1400
6	1540	1446	1540	1670	1670	1670	1670	1040	1530
7	1640	1587	1640	1830	1830	1830	1830	1209	1670
8	1747	1728	1747	2000	2000	2000	2000	1336	1830
9	1860	1869	1860	2200	2200	2200	2200	1477	2000
A	2400	2151	1055	2800	885	885	970	1995	825
B	930	2433	930	810	825	810	810	571	740
C	2247	2010	2400	970	740	2800	2800	2205	2600
D	991	2292	991	885	680	680	885	2437	885
E	2110	459	2110	2600	970	970	2600	1805	2400
F	1055	1091	2247	680	2600	2600	680	2694	680

- Random ANI** When the Random ANI field is checked, the ANI sequence is sent during the transmission at some random time (0 to 15 seconds) after the PTT is pressed. There is no **Lead In Delay** for random ANI transmissions.
- If the transmission is terminated (PTT released or transmit timeout) before the first random ANI has been sent and Trailing ANI is unchecked, then the ANI sequence is sent in the trailing position, subject to the expiry of the **ANI Suppression Time**.
- A valid ANI sequence must be defined in the **ANI Sequence** field.
- Trailing ANI** When the Trailing ANI field is checked, the ANI sequence is sent at the end of the transmission, subject to the expiry of the **ANI Suppression Time**. The ANI sequence is sent after release of the PTT but before any subaudible signalling termination sequence (i.e. CTCSS reverse tone burst, DCS stop code). There is no **Lead In Delay** for trailing ANI transmissions.
- A valid ANI sequence must be defined in the **ANI Sequence** field.
- ANI Suppression Time** The ANI Suppression Time field sets the amount of time between the end of the transmission of the **ANI Sequence** and when it is next transmitted, if the PTT has been pressed. Set this field to between 0 and 155 seconds in steps of 5 seconds.
- Radio Monitor Reset Alert** T2020 radios only.

	When the Radio Monitor Reset Alert field is checked, the radio activates an audible alert when a valid <a href="#">Radio Monitor Reset (RMR) Sequence</a> is received.
Auto Acknowledge Delay	The Auto Acknowledge Delay Time field sets the delay between receiving an incoming Selcall sequence and sending an <a href="#">Auto Acknowledge</a> . Set a value from 100 to 8,000 ms in steps of 100 ms.
Internal Alert Duration	<p>The Internal Alert Duration field sets the maximum duration of the internal audible alert which sounds when an individual Selcall call is received. This alert sounds until either the timer expires or the call is answered. Set a value from 0 to 250 seconds (T2020 radios) in steps of 1 second, or from 0 to 30 seconds (T2010/T2015 radios) in steps of 2 seconds. If set to 0, the radio rings until the call is answered.</p> <p> <b>Note:</b> This setting has no effect on the internal alert that is sounded when a group Selcall call is received. When a group Selcall is received, the radio only rings once. This setting also has no effect on Selcall calls with a <a href="#">Priority Call Control Status</a>, which will ring until answered.</p>
External Alert Duration	<p>The External Alert Duration field sets the maximum duration of the audible alert which sounds an external device when an individual call is received. This external device becomes active only after the <a href="#">External Alert Delay</a> has expired. Set a value from 0 to 250 seconds (T2020 radios) in steps of 1 second, or from 0 to 30 seconds (T2010/T2015 radios) in steps of 2 seconds.</p> <p>For T2010/T2015 radios, the setting in this field has no effect if the <a href="#">Internal Alert Duration</a> has been set to 0 (continuous).</p>
External Alert Delay	<p>T2020 radios only.</p> <p>The External Alert Delay field sets the time the radio waits before activating the external device (e.g. a car horn) after receiving an individual call. Set value from 0 to 250 seconds in steps of 1 second.</p>
External Alert Level	<p>T2020 radios only.</p> <p>The External Alert Level field sets the type of signal provided for the external device (e.g. a car horn). Select either Pulsed or Steady.</p>
Group Format	The Group Format field sets the group format used for group calling. The format selected depends on the system in use. For International, the first tone in the sequence defined cannot be a group tone. Any of the subsequent tones can be the group tone. For Sigtec, the first tone in the sequence defined cannot be a group tone. All following the first group tone must also be a group tone. All radios operating on the Selcall system should use the same group format.
Tone Blanking	The Tone Blanking field enables tone blanking for received Selcall sequences on all Selcall systems. Tone blanking blanks out the tones of a received Selcall sequence so that the user does not hear them. The user may, however, hear the first few tones. The Tone Blanking field has no other effect on Selcall operation.
Car to Car Dialling Length	<p>T2020 radios only.</p> <p>The Car to Car Dialling Length field sets the number of digits that can be dialled from the control head of the radio. Enter a number between 0 and 8, in steps of 1. If set to 0, dialling is disabled. Note that the maximum value that can be entered is equal to the number of Rs in the <a href="#">Tx Format</a>.</p>

## Selcall Muting

T2010/T2015 radios only.

When the Selcall Muting field is checked, the radio only unmutes when a valid Selcall sequence is received. The radio user cannot initiate calls using the PTT unless monitor is active, but can make Selcall calls.

## Selcall Sequences Tab

The tone sequences for Selcall calls are defined in the Selcall Sequences tab. These sequences are then assigned to channels.

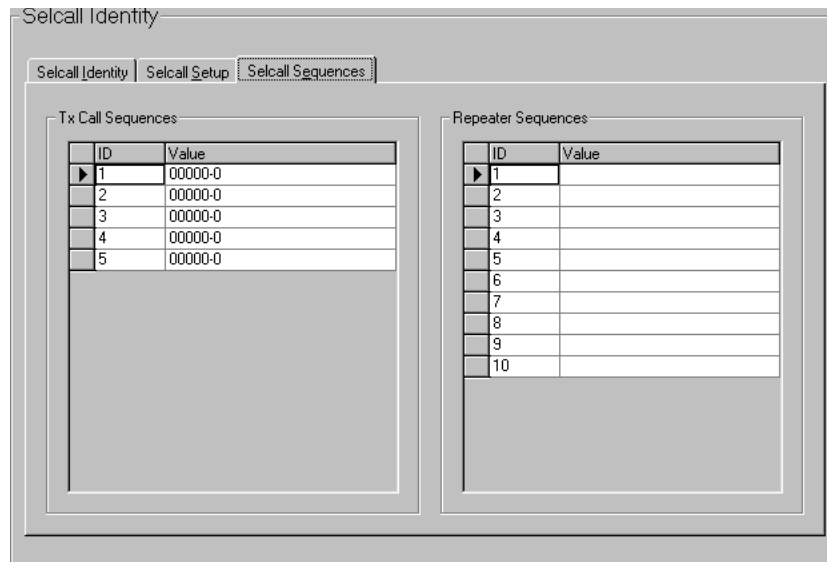

## Tx Call Identity

The Tx Call Identity is used to refer to the associated [Tx Call Value](#), and cannot be shared by any other transmit call identity. For T2010/T2015 radios, up to 4 transmit call identities are available. For T2020 radios, up to 5 transmit call identities are available.

## Tx Call Value

The Tx Call Value field defines the transmit call sequence associated with the [Tx Call Identity](#). The length of the sequence entered must match the length of the R (receiver identity) burst in the [Tx Format](#) field.

Use characters 0 to 9, B, C, D, F or G. The G represents a group tone, which identifies incoming Selcall sequences as group calls.

If status is required, it must come last in the sequence and is separated from the Selcall address by a - (gap). If there is one status digit in the Tx Format then the values 0 to 15 can be used. If there are two status digits used in the Tx Format, then the values 0 to 99 can be entered. If variable status is required (T2020 only), then enter V instead of the status number.

## Repeater Identity

The Repeater Identity is used to refer to the associated [Repeater Value](#), and cannot be shared by any other repeater identity. For T2010/T2015 radios, enter up to 4 repeater identities. For T2020 radios, enter up to 10 repeater identities.

## Repeater Value

The Repeater Sequence field defines the repeater sequence associated with the [Repeater Identity](#). The length of the sequence entered must match the length of the B (repeater identity) burst in the [Tx Format](#) or [Auto Ack Format](#) fields. Use characters 0 to 9, B, C, D, E, F or G (note that G is valid for T2010/T2015 radios only).

## Selcall Features Form

T2020 radios only.

Various advanced Selcall features are selected in the Selcall Features form.

Selcall Features

Features

- Group Dialling
- Group Selective Dialling
- Deferred Calling
- Third Tone Monitor Reset
- Automatic Caller Identification
- A.N.I. Decoding
- Called Unit Status Display
- Rx Call Sub-sequence Decoding
- Received Call Queuing
- Tx Tolerance Factor:

Call Diversion

- Call Diversion
- Call Diversion Channel:
- Call Diversion Status:

### Group Dialling

If the Group Dialling field is checked, then Selcall group calls are permitted. Selcall group calls are made by including group tones in the Selcall sequence to replace all uncommon digits. The digits common to all users in the Selcall group are dialled, then the # key is used as a substitute for the remaining digits in the sequence. For example, dialling 12# sends the sequence 12GGG (5 digit receiver identity in the [Tx Format](#)).

The [Car to Car Dialling Length](#) (Selcall Setup tab) sets the number of digits that can be dialled from the radio control head. This must be greater than 0 before group dialling can be enabled.

### Group Selective Dialling

If the Group Selective Dialling field is checked, then the group tone digit can be dialled individually when dialling a Selcall sequence. This digit is dialled using the \* key to produce a single G in the sequence. For example, dialling 12\*45 sends the sequence 12G45 (5 digit receiver identity in the [Tx Format](#)).

The [Car to Car Dialling Length](#) (Selcall Setup tab) sets the number of digits that can be dialled from the radio control head. This must be greater than 0 before group dialling can be enabled.

### Deferred Calling

If the Deferred Calling field is checked then a Selcall call to a busy channel can be stored and redialed as soon as the channel becomes free. The [Tx Inhibit](#) field (Transmitter Setup form) must be set to Busy or Mute before deferred calling can be enabled.

The deferred calling feature is always active in T2010 radios and is active in T2015 radios as long as the Tx Inhibit field is set to Busy or Mute.

### Third Tone Monitor Reset

If the Third Tone Monitor Reset field is checked then any call carrying tones matching the first three tones of the Rx decode sequence deactivates the radio's monitor, if it is active. The third tone monitor reset option is only valid if there are more than three Rs in the [Rx Format](#) R (receiver identity) burst.

Automatic Caller Identification	<p>If the Automatic Caller Identification field is checked, then the identity of the caller is displayed when an incoming call is received that matches the radio's Rx decode sequence. The caller identity is displayed as a number or as a label.</p> <p>Automatic caller identification only operates when there is a C (caller identity) burst in the <a href="#">Rx Format</a>.</p>
ANI Decoding	<p>When the ANI Decoding field is checked, the identity of any caller matching the radio's <a href="#">Rx Format</a> is displayed. If the Rx Format contains a C (caller identity) burst, then ANI Decoding cannot be enabled.</p>
Called Unit Status Display	<p>When the Called Unit Status Display field is checked, the radio displays any status messages returned with an auto acknowledge sequence from a called radio. The <a href="#">Rx Format</a> must contain an S (status) burst before call unit status display is enabled.</p>
Rx Call Sub-sequence Decoding	<p>When Rx Call Sub-sequence Decoding is checked, the detection and validation of incoming Selcall sequences depends only on the R (receiver identity) burst, and so if the caller identity and status are absent from the incoming sequence, the call is still detected as valid. This feature is useful in areas of marginal signal strength where some of the bursts may be missing or corrupted.</p>
Received Call Queuing	<p>When the Received Call Queuing field is checked, a queue is set for holding up to 10 unanswered Selcall calls. Call queuing can only be enabled when the <a href="#">Automatic Caller Identification</a> field is checked and when there is a C (caller identity) burst in the <a href="#">Rx Format</a>.</p>
Tx Tolerance Factor	<p>The Tx Tolerance Factor field determines how long the radio continues transmitting once the last tone in a Selcall sequence has been transmitted. This extra tail time ensures that the called radio is able to decode the Selcall sequence. Set a value from 0 to 12 in steps of 1, where 0 is the shortest possible tail time.</p>
Call Diversion	<p>If the Call Diversion field is checked then the call diversion feature can be activated from the radio control head. Once call diversion is activated, incoming calls can be diverted to a third party.</p>
Call Diversion Channel	<p>The Call Diversion Channel field sets the channel the radio switches to so that communication can be established when a called radio is in call diversion mode. Select a channel identity from the combo box.</p>
Call Diversion Status	<p>The Call Diversion Status field sets the status digit that identifies the status of the radio when it is in call diversion mode. Enter a number between 0 and 15 if a single status digit is used in the <a href="#">Rx Format</a>, or 0 to 99 if a double status digit is used in the Rx Format.</p> <p>The status number entered in this field mirrors the status number defined in the <a href="#">Call Diversion Status</a> field (Selcall Status form). This status value cannot be the same as any other control status value entered on the Selcall Status form.</p>

## Selcall Status Form

T2020 radios only.

The following status features are set in the Selcall Status form.

- Control Status Digits: these initiate a particular radio operation, such as activate/deactivate the stun function.

- **Status Digits:** these can be added at the end of a Selcall sequence to indicate the caller's present activity or status. The digits are associated with a descriptive label, such as "AT LUNCH".

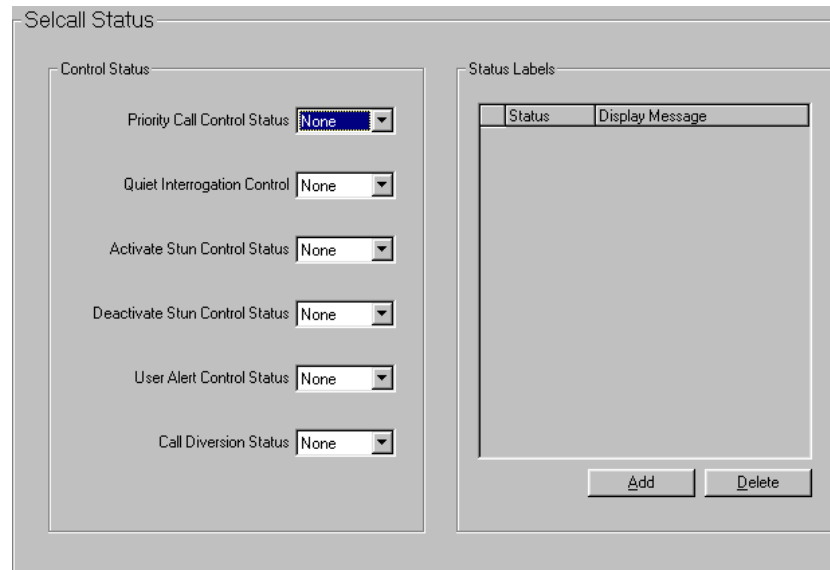

#### Priority Call Control Status

The Priority Call Control Status field sets the status digit that when received identifies a call as a priority call. Enter None if no priority call detection is required. Enter a number from 0 to 15 if a single status digit is used in the [Rx Format](#), or 0 to 99 if a double status digit is used in the Rx Format. This status value cannot be the same as any other control status value.

#### Quiet Interrogation Control

The Quiet Interrogation Control field sets the status digit that when received causes the radio to transmit the auto acknowledge sequence without alerting the radio user to the receipt of the Selcall sequence. Enter None if no quiet interrogation control status detection is required. Enter a number from 0 to 15 if a single status digit is used in the [Rx Format](#), or 0 to 99 if a double status digit is used in the Rx Format. This status value cannot be the same as any other control status value.

#### Activate Stun Control Status

The Activate Stun Control Status field sets the status digit that when received causes the radio to cease normal operation. The radio resumes normal operation when the [Deactivate Stun Control Status](#) is received. Enter None if no activate stun control status detection is required. Enter a number from 0 to 15 if a single status digit is used in the [Rx Format](#), 0 to 99 if a double status digit is used in the Rx Format. This status value cannot be the same as any other control status value.

#### Deactivate Stun Control Status

The Deactivate Stun Control Status field sets the status digit that when received causes a stunned radio to resume normal operation. Enter None if no deactivate stun control status detection is required. Enter a number from 0 to 15 if a single status digit is used in the [Rx Format](#), or 0 to 99 if a double status digit is used in the Rx Format. This status value cannot be the same as any other control status value.

This field must be given a status value if the [Activate Stun Control Status](#) field has a status value.



User Alert Control Status	<p>The User Alert Control Status field sets the status digit that causes the radio to issue an audible alert. Enter None if no user alert control status detection is required. Enter a number from 0 to 15 if a single status digit is used in the <a href="#">Rx Format</a>, or 0 to 99 if a double status digit is used in the Rx Format. This status value cannot be the same as any other control status value.</p>
Call Diversion Status	<p>The Call Diversion Status field sets the status digit that identifies that a radio is in call diversion mode. Enter None if no call diversion control status detection is required. Enter a number from 0 to 15 if a single status digit is used in the <a href="#">Rx Format</a>, or 0 to 99 if a double status digit is used in the Rx Format. This status value cannot be the same as any other control status value.</p> <p>This field is only available if the <a href="#">Call Diversion</a> field has been checked in the Selcall Features form. The status value set in the Call Diversion Status field mirrors the status value set in the <a href="#">Call Diversion Status</a> field (Selcall Features form).</p>
Status Labels	<p>The Status Labels fields set the status message which can be sent with a call to indicate the current activity of the radio operator. The number of status messages available depends on the number of status digits in the <a href="#">Tx Format</a>. If there is one status digit in the Tx Format, then up to 16 status messages can be defined. If there are two status digits used in the Tx Format, then up to 100 status messages can be defined.</p> <p>Select the Add button to add a status message, or select the Delete button to delete the currently selected status message.</p>
Status Label Identity	<p>The Status field sets the status digit that is transmitted. If the <a href="#">Tx Format</a> has one S, then there are 16 possible status digits, numbered 0 to 15. If the Tx Format has two Ss, there are 100 possible status digits, numbered from 0 to 99. Select the Add button to add the next available status identity.</p>
Status Label Display Message	<p>Enter an 8 character status label to correspond with each status identity, chosen from A to Z 0 to 9 * + - &lt; &gt; / \ space.</p> <p>The status labels defined in this field are also listed in the <a href="#">New Status</a> field (Alpha Symbols form), where they can be associated with an alpha symbol.</p>

## Selcall Emergency Form

T2020 radios only.

The behaviour of the radio while in emergency mode is set in the Selcall Emergency form. An emergency call can be assigned to the control head auxiliary key (Key Settings form), which is then used to activate emergency mode. Once emergency mode is activated, an emergency sequence is transmitted. Emergency mode is made up of three parts.

- **Emergency Activation:** Emergency mode is requested and an emergency Selcall sequence is transmitted.
- **Emergency Callout:** Once emergency mode has been requested, the radio begins emergency callout, where the emergency sequence is transmitted either once, or repeatedly until an acknowledge sequence is received.
- **Emergency Transmit/Receive Cycling:** After emergency callout, the radio may then cycle between receiving and transmitting, allowing the recipient of the emergency call to monitor activity near the radio.

**Emergency Sequence**

The sequence defined in the Emergency Sequence field is the Selcall sequence that is transmitted when an emergency call is made. The sequence entered in this field mirrors the sequence defined in the [Emergency Sequence](#) field (Selcall Identity tab). If the sequence is modified in one form, the sequence appearing in the other is automatically updated.

The length of the emergency sequence matches the length of the R burst (receiver identity) in the [Tx Format](#). Use characters 0 to 9, B, C, D, F or G to define the emergency Selcall sequence.

If status is required, it must come last in the sequence and is separated from the Selcall address by a - (gap). If there is one status digit in the Tx Format then the values 0 to 15 can be used. If there are two status digits used in the Tx Format, then the values 0 to 99 can be entered. If variable status is required (T2020 only), then enter V instead of the status number.

**RMR Sequence**

The sequence defined in the RMR Sequence field sets the Selcall sequence that, when received, deactivates monitor and squelch override. The sequence entered in this field mirrors the sequence defined in the [Radio Monitor Reset \(RMR\) Sequence](#) field (Selcall Identity tab). If the sequence is modified in one form, the sequence appearing in the other is automatically updated.

The sequence entered must match the R burst (receiver identity) in the Selcall system's [Rx Format](#). Use characters 0 to 9, B, C, D or F. A \* wild card tone can also be used, representing any other tone.

**Emergency Channel**

The Emergency Channel field determines the channel the radio switches to when the emergency call is made. Select a [Channel ID](#) from the combo list to send the emergency call sequence on that channel. If None is selected, the emergency call sequence will go out on the current channel.

**Mute Received Audio**

When the Mute Received Audio field is checked, the radio's receive audio remains muted while in emergency mode and so the radio does not broadcast noise that may draw attention in an emergency situation. If unchecked, the mute state in emergency mode obeys the standard muting operation.

Alarm Tone	The Alarm Tone field sets the trailing alarm tone to be sent with the emergency sequence. Select any hex character (0-9, A-F). Select None if you do not want to transmit the alarm tone.
Callout Cycling	The setting of the Callout Cycling field determines how the emergency call is sent. If checked, the radio resends the emergency Selcall sequence periodically until a call is received that matches one of the radio's Rx decode sequences and does not contain a control status. If unchecked, the radio transmits the emergency sequence once, then leaves the emergency callout state, either returning to normal operation or entering the emergency cycling state.
Tx/Rx Cycling	This field sets whether the radio enters an emergency cycling state after the emergency sequence is acknowledged. This allows the recipient of the emergency call to monitor activity near the radio. If checked, the radio repeatedly cycles between transmit and receive until it is switched off and then on. The period of transmit and receive is set in the <a href="#">Receive/Transmit Time</a> fields. If unchecked, the radio returns to normal operation after the emergency callout.
Receive/Transmit Time	The Receive Time and Transmit Time fields set the amount of time the radio transmits and receives while in emergency cycling mode. For both the Transmit Time and the Receive Time fields, set a value from 0 to 30 seconds in steps of 1 second. If the Transmit Time field is set to 0, the radio will only receive while in emergency cycling mode.  These fields are only selectable if <a href="#">Tx/Rx Cycling</a> is checked.

# Setting Up Channels and Scan Groups

This section contains detailed information on setting up channels and scan groups.

## Channels Form

The main settings for channels are set up in the Channels form. The Channels form for T2010/T2015 radios is shown below.

The screenshot shows a window titled "Channels" containing a table with the following data:

ID	Rx Freq	Tx Freq	Rx Sig	Tx Sig	Tx Call	Repeater	Power	Scan
1	000.00000	000.00000	None	None	None	None	High	No

Below the table are four buttons: Add, Insert, Repeat, and Delete. At the bottom, there is a "Settings" section with the following options:

- BCD Channel Selection
- BCD Polarity Inverted
- Off Hook Scanning
- Scan Hold Time

The Channels form contains default values for one channel. Select the Add button to add a new channel, select the Delete button to delete the currently selected channel, or select the Repeat button to duplicate the current channels settings, except for the Channel ID and Channel Name fields.

There must be at least one channel in the list. The number of channels permitted depends on the radio model, as follows:

- T2010: up to 24 channels
- T2015: up to 24 channels
- T2020: up to 100 channels
- T2020 firmware version 7.01 or higher: up to 1200 channels.

### Channel ID

The channel ID field sets the channel number, which cannot be shared by any other channel or scan group.

- For T2010 radios, set up to 24 channel identities, between 1 and 24.
- For T2015 radios, set up to 24 channel identities, between 1 and 24.
- For T2020 radios, set up to 100 channel identities, between 1 and 255.
- For T2020 radios (firmware version 7.01 or higher), set up to 1200 channel identities, between 1 and 4999.

### Channel Name

T2020 radios only.

The Channel Name field sets the name which is appears in the control head display on T2020 radios when the radio is in channel mode. The radio enters channel entry or channel select mode when the radio channel key is pressed.

Enter a name of up to 8 characters, chosen from A to Z 0 to 9 \* + - < > / \ space.

A default name is generated from the channel identity. For example, the first channel defaults to CHAN1.



**Note:** Do not allocate the same name for different channels or scan groups, since both are accessed in the same way.

#### Rx and Tx Frequencies

The Rx Freq field sets the receive frequency (in MHz) for the channel, and the Tx Freq field sets the transmit frequency (in MHz). For each channel, enter a frequency within the radio’s frequency band that is a multiple of 5 kHz or 6.25 kHz.

The minimum channel spacing is dependant on the radio band and IF bandwidth. The letter in the sixth position in the radio part number (first after the hyphen) indicates the radio’s frequency band, as outlined in the table below.

Band	Receive Frequency (MHz)	Transmit Frequency (MHz)
0	500-530 MHz	500-530 MHz
1	220-270 MHz	220-270 MHz
2	66-88 MHz	66-88 MHz
3	136-174 MHz	136-174 MHz
4	175-225 MHz	175-225 MHz
5	400-470 MHz	400-470 MHz
6	450-520 MHz	450-520 MHz
7	330-366 MHz	330-366 MHz
8	800-870 MHz	800-870 MHz
9	360-400 MHz	360-400 MHz

#### Rx and Tx Signalling

The Rx Sig field sets the subaudible signalling the radio must receive before the activity is regarded as valid and the mute opened. The Tx Sig field sets the subaudible signalling that accompanies each transmission made on the channel.

For both fields, select the required frequency from the drop-down list. Both fields must be either CTCSS (tones starting with C) or DCS (tones starting with D). Leave these fields set to None if no subaudible signalling is used on the channel.

#### Tx Call

The Tx Call field provides a list of transmit Selcall sequence identities. These are identities that have been defined in the [Tx Call Identity](#) field (Selcall Sequences tab). Select the transmit call identity required from the drop-down list. To disable Selcall on the channel, select None.

Repeater	The Repeater field provides a list of Selcall repeater sequence identities. These are identities that have been defined in the <a href="#">Repeater Identity</a> field (Selcall Sequences tab). Select the repeater identity required from the drop-down list. To transmit no repeater sequence on the channel, select None.
Power	The Power field sets the transmit power level. Select a power level setting of Off, Low High or Max (maximum - T2020 radios only), within the limits permitted for the region in which the radio operates.
Bandwidth	T2020 radios only  The Bandwidth field sets the transmitter deviation and the receiver audio sensitivity for systems using different channel spacing. Select either Narrow (narrowband) or Wide (wideband) for each channel.
Scan	T2010/T2015 radios only.  Select Yes for the channel to be included in the scan operation. While scanning, the radio cycles through all the included channels until it detects valid activity. When activity is detected, the radio stops on that channel until the activity stops, then waits for the time set in the <a href="#">Scan Hold Time</a> field before returning to scan mode.  If <a href="#">Enhanced Scanning</a> (Specifications form) is checked for T2015 radios, then two additional options are available, Pri and Sec. Both options add the channel to the scan list, 'Pri' specifies that the channel is the primary priority scan channel and 'Sec' specifies that the channel is the secondary priority scan channel. Scan types in the <a href="#">Enhanced Scan Form</a> will take precedence over these settings, unless the radio is switched on while the PTT is pressed.
BCD Channel Selection	T2010/T2015 radios only.  When the BCD Channel Selection field is checked, it is possible to select the radio channel using the internal BCD channel select lines. In this case, the control head channel keys are disabled.
BCD Polarity Inverted	T2010/T2015 radios only.  When the BCD Polarity field is checked, a high voltage input is considered to be a '0' and a low voltage input is considered to be a '1'.
Off Hook Scanning	T2010/T2015 radios only.  When the Off Hook Scanning field is checked, scanning is possible when the hookswitch is open.
Scan Hold Time	T2010/T2015 radios only.  The Scan Hold Time field determines how long the radio remains on a channel after valid activity finishes, before scanning is resumed. Enter a time between 0 and 15 seconds in steps of 1 second.

## Scan Groups Form

T2020 radios only.

Scanning and voting groups are set up in the Scan Groups form, which is divided into two sections:

- Scanning and voting groups are set in the [Scan Group Members](#) grid.
- General scanning and voting rules are set in the [Scan Settings](#) section.

GroupID	GroupName	Type	User	1	2	3	4	5	6
2	GROUP02	S	No	1	None	None	None	None	None

Buttons: Add, Repeat, Delete

Scan Settings:

- Hidden Channels
- Off Hook Scanning
- Group Hold Time: 5
- Voting Lead in Delay: 60
- Voting Polling Interval: 60

## Scan Group Members Grid

Scanning and voting groups are set up in the Scan Group Members Grid. Up to 16 scan groups are permitted for T2020 radios, and up to 240 scan groups for T2020 radios with firmware version 7.06 or higher.

Select the Add button to add a scan group, select the Delete button to delete the currently selected scan group, or select the Repeat button to duplicate the current scan group's [Type](#) and [User](#) fields and the [scan group membership list](#).

**Scan Group ID** The scan Group ID field sets the scan group identity, which cannot be shared by any other channel or group. For T2020 radios, set up to 20 scan group identities, between 1 and 255. For T2020 radios with firmware version 7.06 or higher, you can set up to 240 scan group identities, between 1 and 4999.

**Scan Group Name** The scan group Name field sets the group name which appears in the radio control head display window when the radio is in channel selection mode. The radio enters channel mode when the radio channel key is pressed. Enter a name of up to 8 characters, chosen from A to Z 0 to 9 \* + - < > / \ space.

A default name is generated from the scan group identity. For example, if three channels are defined, then the first scan group defaults to GROUP4.



**Note:** Do not allocate the same name for different scan groups or channels since both are accessed in the same way.

**Scan Group Type** The Type field sets the type of scanning/voting used for the group.

### Options:

- Scanning (S). See [page 117](#) for more information.
- Priority Scanning (P). See [page 117](#) for more information.
- Dual Priority Scanning (DP). See [page 117](#) for more information.
- Voting (V). See [page 118](#) for more information.
- Voting With Signalling (VS). See [page 118](#) for more information.
- Double Voting (D). See [page 118](#) for more information.
- Double Voting With Signalling (DS). See [page 118](#) for more information.

**Scan Group User Reprogram** The User field determines whether the scan group can be reprogrammed by the radio user. If checked, the radio user can reprogram the group. If unchecked, the scan group can only be changed by reprogramming the radio.

**Scan Group Membership List** Member channels are added to scan groups in the group membership list. Select a channel identity from the drop-down list. There must be at least 2 and no more than 16 entries for each scan group, and a channel can appear in a particular scan group only once. There can be no gaps in the list of member channels.

For scanning groups (Group Type S, P or DP), the first channel in the group membership list is the home channel. For priority scanning (PS), the first channel is the priority channel. For dual priority scanning (DPS), the first and second channels are the priority channels, and the first channel listed has higher priority than the second.

For voting groups (V, VS, D and DS), the first channel in the group membership list is the home channel if no other channel has been voted as the home channel.

## Scan Settings

Set general scanning and voting rules in Scan Settings.

[Hidden Channels](#)

[Off Hook Scanning](#)

[Group Hold Time](#)

[Voting Lead In Delay](#)

[Voting Polling Interval](#)

**Hidden Channels** Scan groups contain between 2 and 16 channels, and normally these channels can also be accessed individually.

When the Hidden Channels field is checked, channels that are assigned to a scan group are hidden from the user and so cannot be selected individually. This setting has the effect of making a group of channels appear as one channel. If you wish to access the channels within a group, uncheck the Hidden Channels field.

**Off Hook Scanning** The Off Hook Scanning field sets whether scanning is allowed when the hookswitch is open. If the user initiates a call while the radio is off hook scanning, the radio transmits on the home channel.

**Group Hold Time** The Group Hold Time field specifies the length of the pause before scanning resumes once valid activity has ceased on a channel.

Enter a time between 0 and 250 seconds in steps of 1 second. If set to 0, the hold timer is not enabled regardless of channel activity and scanning resumes immediately after a channel becomes invalid, which would not allow for any pauses in a conversation.

**Voting Lead In Delay** The Voting Lead In Delay field sets the delay between the radio detecting activity on a channel in a voting group and voting taking place. The voting lead in delay gives the repeaters in the system time to come to full power. Enter a value between 0 and 2550 ms in steps of 10 ms.



Voting Polling Interval

The Voting Polling Interval field sets the time between votes when channels are carrying invalid activity. Enter a value between 1 and 250 seconds in steps of 1 second.

## Enhanced Scan Form

T2015 radios only.

The Enhanced Scan form can read or program enhanced scanning features such as the temporary scan list and channels assigned to the memory keys. You can also define whether these settings are cleared when the radio is switched off. To access this form, [Enhanced Scanning](#) must be checked in the Specifications form.

Any settings in this form that are programmed into the radio will hold precedence over settings in the [Channels Form](#) and [Key Settings Form](#) until either the radio is turned off (and the [Clear Temporary Scan Allocation at Switch Off](#) field is selected), or the radio is turned on while the PTT pressed.

ID	Type
1	No

Clear Temporary Scan Allocation at Switch Off

When this field is checked, any modifications the user has made to the scan list (and channel memory keys) will be lost when the radio is switched off. Selecting this field will disable the other fields on this form.

Holding down the PTT when the radio is turned on will clear the user's modifications, resetting the scan list to the default defined in the [Channels Form](#).

Uncheck this field if you want the radio to remember any changes when the radio is switched off.

User Programmable Memory One Channel

This is the channel that the user has programmed to be selected when memory key [M1] is pressed.

User Programmable Memory Two Channel

This is the channel that the user has programmed to be selected when memory key [M2] is pressed.

## Enhanced Scanning Grid

The Enhanced Scanning Grid lists all channels and enhanced scan settings the user has programmed from the front panel of the radio. These can be read here for diagnostic and maintenance purposes, or the radio can be preprogrammed with new data.



**Note:** These settings will be reset to the default settings defined in the [Channels Form](#) > [Scan](#) field if the radio is switched off and the [Clear Temporary Scan Allocation at Switch Off](#) field is checked, or switched on while the PTT is pressed.

Enhanced Scanning ID

The Enhanced Scanning ID field lists all the channel IDs specified in the [Channels Form](#).

Enhanced Scanning Type

The Enhanced Scanning Type field lists whether or not the channel is included in the scan operation, and which channels have priority.

The following options are available:

- Yes: the channel will be included in the scan list.
- No: the channel will not be included in the scan list.
- Pri: the channel will be included in the scan list, as the primary priority scan channel.
- Sec: the channel will be included in the scan list, as the secondary priority scan channel.

## Birdie Channels Form

T2020 radios only.

Birdie channels are identified in the Birdie Channels form. A birdie channel is a channel on which receiver sensitivity is degraded by internal interference. This interference is eliminated from birdie channels by activation of birdie killer circuitry.

Channel ID	Name
1	CHAN1

Select the Add button to add a channel or select the Delete button to delete the currently selected channel.

Channel ID	Select the required channel identity from the drop-down list. The channel identities available have been previously added in the Channels form.  Note that if the receive frequency of a birdie channel is changed in the Channels form, then that channel is removed from the birdie channels list.
Channel Name	Once a channel identity has been selected in the <a href="#">Channel ID</a> field, the channel associated with that identity appears in the Channel Name field.

# Special Features

---

This part contains detailed information on setting up special features such as alpha symbols, CCI operation, DTMF and economy mode.

## Power Saving (Conventional) Form

Economy mode settings are made in the Power Saving form, allowing the current drawn by the radio to be reduced after a specified period of inactivity. Any traffic on the radio returns it to a fully operational state. On T2020 radios, the display backlighting may dim or switch off while in economy mode, depending on the setting in the [User Selectable](#) form.

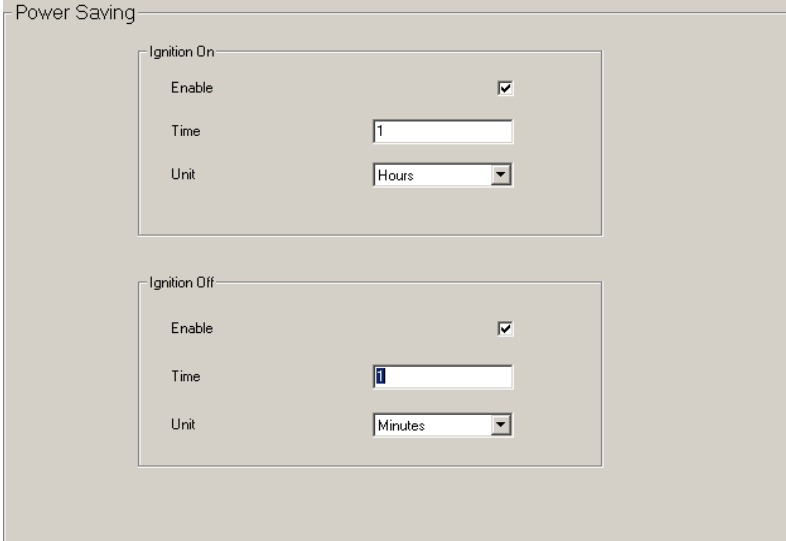

The screenshot shows a 'Power Saving' configuration window. It is divided into two main sections: 'Ignition On' and 'Ignition Off'. Each section contains three controls: an 'Enable' checkbox (both checked), a 'Time' text input field (containing '1' in both), and a 'Unit' dropdown menu (set to 'Hours' for Ignition On and 'Minutes' for Ignition Off).

### Ignition On

The Ignition On fields set the amount of time before the radio enters economy mode when the vehicle ignition is on (ignition sense line is at 12 volts). Select the Enable check box, enter a value in Time text box and specify a Unit in the combo box (Secs, Mins, Hrs). The minimum value is 0 and the maximum is 18 hours or 59 minutes/seconds. Uncheck the Enable field to disable economy mode.

### Ignition Off

The Ignition Off fields set the amount of time before the radio enters economy mode when the vehicle ignition is off (ignition sense line is at 0 volts). Select the Enable check box, enter a value in the Time text box and specify a Unit in the combo box (Secs, Mins, Hrs). The minimum value is 0 and the maximum is 18 hours or 59 minutes/seconds. Uncheck the Enable field to disable economy mode.

## DTMF Form

T2020 radios only.

DTMF tone encoding and DTMF dialling features are set in the DTMF form.

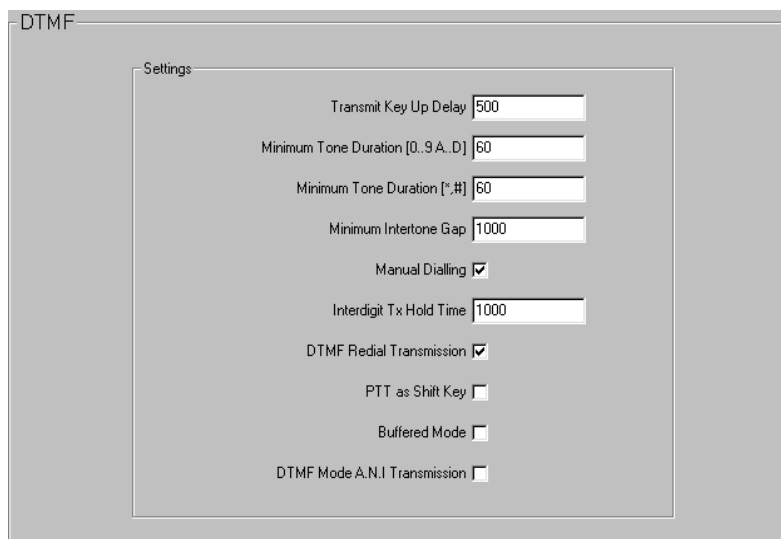

Transmit Key Up Delay	The Transmit Key Up Delay field sets a delay for the start of tone transmissions so that a repeater has time to stabilise. Enter a value from 10 to 2550 ms in steps of 10 ms.
Minimum Tone Duration (0-9, A-D)	The Minimum Tone Duration (0-9, A-D) field sets the minimum amount of time tones 0 to 9 and A to D are encoded. Enter a value from 8 to 1020 ms in steps of 4 ms.
Minimum Tone Duration (*, #)	The Minimum Tone Duration (*, #) field sets the minimum amount of time tones * and # are encoded. Enter a value from 8 to 1020 ms in steps of 4 ms.
Minimum Intertone Gap	The Minimum Intertone Gap field sets the minimum amount of time between encoded tones. Enter a value from 10 to 2550 ms in steps of 10 ms.
Manual Dialling	The Manual Dialling field is checked if DTMF calls are to be made from the control head numeric keypad. If unchecked, DTMF calls can still be made using alphanumeric symbols.
Interdigit Tx Hold Time	The Interdigit Tx Hold Time field determines how long the radio keeps transmitting between the encoding of each tone. This provides a delay for the user to dial the next digit without transmission stopping and restarting again. Some systems require continuous transmission between DTMF tones and therefore a long hold time. Enter a value between 10 and 2550 ms, in steps of 10 ms.
DTMF Redial Transmission	When the DTMF Redial Transmission field is checked, the user can retransmit the last DTMF call by pressing the enter key when in DTMF dialling mode.  When the radio enters DTMF dialling mode and this function is enabled, the DTMF string transmitted when the radio was last in DTMF dialling mode is displayed. If this is the string the user wishes to transmit, they only have to press the enter key to transmit the string again.
Buffered Mode	If Buffered Mode is checked, the DTMF sequence is stored as it is dialled, and transmitted when the Enter key is pressed. Uncheck the Buffered Mode checkbox to encode and transmit the DTMF tones as each digit is dialled.

### PTT as Shift Key

If the PTT as Shift Key field is checked, the PTT can be used as a shift key in conjunction with the numeric keypad to dial tones A to D.

PTT +  = A

PTT +  = B

PTT +  = C

PTT +  = D

For example, pressing the PTT key, holding it, then pressing the  key enters tone A in the DTMF string.

### DTMF Mode ANI Transmission

If the DTMF Mode ANI Transmission field is checked, the ANI sequence for the current channel can still be sent when a DTMF call is made. Some systems may experience interference if an ANI sequence is sent during a DTMF transmission, and in this case this field should be disabled.

## Alpha Symbols Form

T2020 radios only.

In the Alpha Symbols form, a list of labels is defined and each label is associated with a channel or scan group, a Selcall sequence or DTMF string, a status message, or any combination of these items. The list of alpha symbols can be accessed by the radio user in alphanumeric entry mode, and a maximum of 20 alpha symbols can be set.

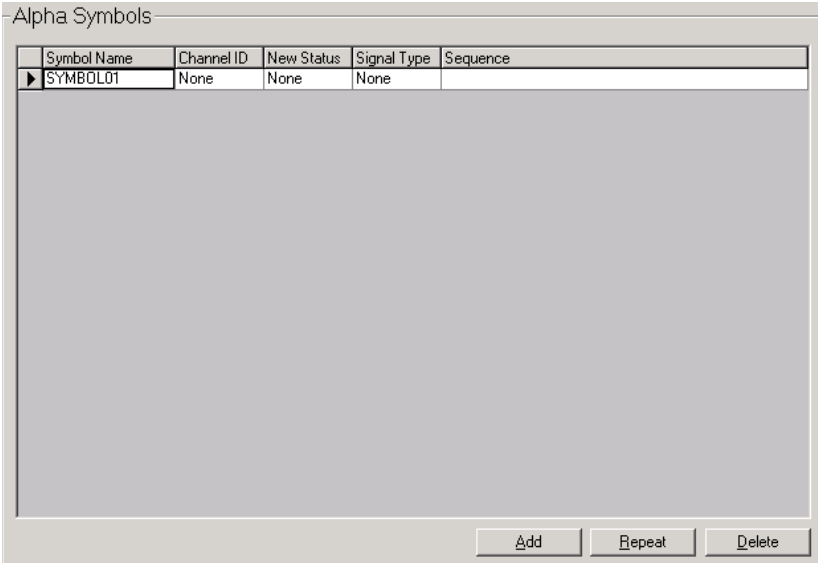

The screenshot shows a window titled "Alpha Symbols" containing a table with the following data:

Symbol Name	Channel ID	New Status	Signal Type	Sequence
► SYMBOL01	None	None	None	

At the bottom of the window are three buttons: "Add", "Repeat", and "Delete".

Select the Add button to add a new alpha symbol, select the Delete button to delete the currently selected alpha symbol, or select the Repeat button to duplicate the current alpha symbol's [Channel ID](#), [New Status](#), [Signal Type](#) and [Sequence](#) fields.

### Symbol Name

The Symbol Name field defines an alphanumeric name for each symbol, and must be unique. Enter up to 8 characters, chosen from A to Z 0 to 9 \* + - < > / \ space.

Because the user must be able to spell out the symbol name using the radio keypad, the characters allowed for the symbol name are different than for other labels. A default name is generated when the Add button is selected, with the first symbol name defaulting to SYMBOL01.

Alpha Symbol  
Channel ID

The Channel ID field sets the channel or scan group number ([Channels](#) and [Scan Groups](#) forms) to be selected when the alpha symbol is selected. Select a channel or scan group identity from the drop-down list. Select None if the channel is not to be changed when the alpha symbol is selected.

Alpha Symbol  
New Status

The New Status field sets the status message to be transmitted when the alpha symbol is selected. Enter None for no new status, or select a control status label of an existing status message from the drop-down list (defined in the [Selcall Status](#) form).

Selcall hardware must be installed in the radio before the status message feature can be used.

Alpha Symbol  
Signal Type

The Signal Type field sets a call signalling type for the alpha symbol, which determines the signalling sequence used when the symbol is activated. Enter Selcall, DTMF or None.

Selcall or DTMF hardware must be installed in the radio before the signalling Type field can be set to either Selcall or DTMF.

If the [New Channel](#) field is set to None and signalling type is set to Selcall, then the Selcall option must be fitted or the call assigned to the symbol is not transmitted. If the New Channel field is set to a specific channel, then a Selcall system must be assigned to that channel or the Selcall call assigned to the symbol will not be transmitted.

Alpha Symbol  
Sequence

The Sequence field sets the Selcall sequence or DTMF string that is transmitted when the alpha symbol is selected. The signalling [Type](#) field must be set to Selcall or DTMF before the signalling number can be set.

If the signalling Type field is set to Selcall, enter a Selcall sequence using characters 0 to 9, B, C, D, F or G. The G represents a group tone, which identifies incoming Selcall sequences as group calls. The length of the sequence entered must match the length of the R (receiver identity) burst in the [Tx Format](#) field.

If the signalling Type field is set to DTMF, enter a valid DTMF string of up to 32 characters, using 0 to 9, A to D \* #.

## CCI Setup (Conventional) Form

T2020 radios only.

The computer controlled interface (CCI) allows the radio to be used for data transmission or to be remotely controlled by computer equipment. This form sets the parameters for the radio's communications ports.

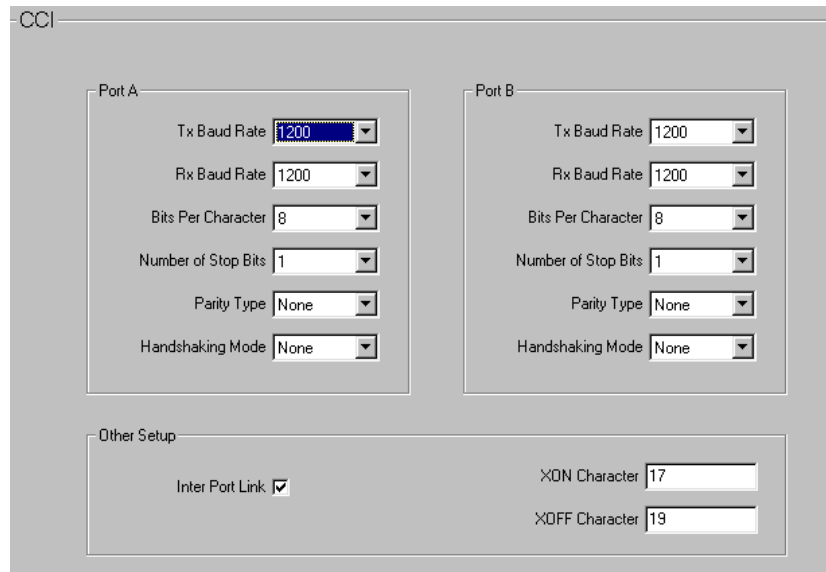

**Tx Baud Rate** The Tx Baud Rate fields set the required transmit baud rate for the CCI interface port. Select the required rate from the combo box. This will usually be the same as the receive baud rate setting for the port.

**Rx Baud Rate** The Rx Baud Rate fields set the required receive baud rate for the CCI interface port. Select the required rate from the combo box. This will usually be the same as the transmit baud rate setting for the port.

**Bits Per Character** The Bits Per Character fields set the required data length. Select either 7 or 8 bit ASCII from the combo box for each port.

**Number Of Stop Bits** The Number of Stop Bits fields set the number of stop bits to append to each character. Select either 1 or 2 from the combo box for each port.

**Parity Type** The Parity Type fields set the required parity checking type. Select Odd, Even or None from the combo box for each port.

**Handshaking Mode** The Handshaking Mode fields sets the handshaking mode for Ports A and B. Handshaking allows control over the flow of data being sent and prevents data from being lost between the radio and the computer equipment communicating with it in CCI mode. Select Software, Hardware or None from the combo box for each port. If Software is selected, values must be added in the XON Character and XOFF Character fields.

**Inter Port Link** The Inter Port Link field is used to switch the CCI into or out of transparent mode. If checked, the CCI is in transparent mode, and the data flows directly from port A to port B. If unchecked, the CCI operates as normal.

**XON/OFF Character** The XON Character and XOFF Character fields are used if Software Handshaking has been selected in the [Handshaking Mode](#) field. XON Character sets the character that indicates the start of a flow of data, and XOFF Character sets the character that indicates the end of a flow of data. Set both fields to a hexadecimal number between 0 and FF.



# Radio Interface Options

This part contains detailed information setting radio interface options, such as auxiliary key settings and user function menu options.

## Key Settings Form

The operation of various radio control head keys is set in the Key Settings form. The Key Settings form for T2010/T2015 radios is shown below.

The screenshot shows the 'Key Settings' form for T2010/T2015 radios. It is divided into three sections: 'Aux Key Settings', 'Channel Key Settings', and 'Call Key Settings'. In the 'Aux Key Settings' section, the 'Key Operation' is set to 'Latching'. In the 'Channel Key Settings' section, 'Channel Selection Keys' is checked, and both 'Memory Key 1' and 'Memory Key 2' are set to 'None'. In the 'Call Key Settings' section, 'Key Operation' is checked.

The Key Settings form for T2020 radios is shown below.

The screenshot shows the 'Key Settings' form for T2020 radios. It is divided into two sections: 'Aux Key Settings' and 'Call Key Settings'. In the 'Aux Key Settings' section, 'Key Operation' is set to 'One Touch', 'Channel/Group ID' is 'None', 'New Status' is 'None', 'Signal Type' is 'Selcall', and 'Signal Number' is an empty text field. In the 'Call Key Settings' section, 'Key Operation' is unchecked.

### Key Operation

The Key Operation field sets the way the radio behaves when the control head auxiliary key is pressed. The options available in the combo box are dependant on the radio model.

- Momentary: A press of the auxiliary key activates the internal AUX line on the options connector while the key is depressed. This can be used to activate an option, such as Selcall.
- Latching: A press of the auxiliary key toggles the internal AUX line on the options connector on and off. This can be used to turn an option such as a scrambler on and off.
- External (T2010/T2015 only): The auxiliary key activates an external alert device (Selcall hardware installed).
- Emergency (T2020 only): A press of the auxiliary key activates the Selcall emergency function (Selcall hardware installed).
- One Touch (T2020 only): When the auxiliary key is pressed, the radio sends a predefined call. The parameters for this call are set in the [Channel/Group ID](#), [New Status](#), [Signal Type](#) and [Signal Number](#) fields.

Channel Selection Keys	<p>T2010/T2015 radios only</p> <p>The Channel Selection Keys field enables or disables channel selection from the front panel. Clear this checkbox to disable the channel keys (T2010/T2015) and channel memory keys (T2015) on the front panel, for external channel selection.</p>
Memory Key Operation	<p>T2015 radios only.</p> <p>The Memory Key 1 and Memory Key 2 fields associate the control head memory keys with a channel defined in the Channels form. Select None for the channel to remain unchanged, or select the required channel identity from the combo box.</p>
Channel/Group ID	<p>T2020 radios only.</p> <p>The Channel/Group ID field is only available when the <a href="#">Key Operation</a> field is set to One Touch. Select None if the channel is to remain unchanged, or select the required channel or scan group identity from the drop-down list.</p>
New Status	<p>T2020 radios only.</p> <p>The New Status field is only available when the <a href="#">Key Operation</a> field is set to One Touch and Selcall hardware is installed. This field sets the status to be selected when the one touch call is made. Enter None for no new status, or select a control status label of an existing status message from the drop-down list (defined in the Selcall Status form).</p>
Signal Type	<p>T2020 radios only.</p> <p>The Signal Type field is only available when the <a href="#">Key Operation</a> field is set to One Touch and sets a call signalling type for the one touch auxiliary key call. Set to None, Selcall (Selcall hardware installed) or DTMF (DTMF hardware installed).</p>
Signal Number	<p>T2020 radios only.</p> <p>The Signal Number field is only available when the <a href="#">Key Operation</a> field is set to One Touch. This field sets the Selcall sequence or DTMF string to be sent when the one touch call is made. The <a href="#">Signal Type</a> field must be set to Selcall or DTMF before the Signal Number field can be set. Enter a valid Selcall sequence or DTMF string.</p>

**Key Operation** The call key can be used to make a call to an assigned user if Selcall hardware is installed in the radio. If checked, the radio is able to initiate a Selcall call using the call key. If unchecked, the radio is unable to initiate a Selcall call using the call key.

## User Selectable Form

Initial settings for various radio features and options are set in the User Selectable form. The In User Menu check boxes select items for the T2020 radio's user function menu.

The screenshot shows a window titled "User Selectable" containing a "Parameters" section. This section is organized into two columns: "Initial Setting" and "In User Menu".

Parameter	Initial Setting	In User Menu
Economiser Backlighting Level	<input type="checkbox"/>	<input checked="" type="checkbox"/>
Normal Backlighting Level	Full	<input checked="" type="checkbox"/>
External Mute	<input type="checkbox"/>	<input type="checkbox"/>
External Alert Function	<input checked="" type="checkbox"/>	<input type="checkbox"/>
Keypress Confidence Tones	<input checked="" type="checkbox"/>	<input checked="" type="checkbox"/>
Keypress Confidence Tones Level	High	<input checked="" type="checkbox"/>
Short Status Display	<input type="checkbox"/>	<input type="checkbox"/>
DTMF Auto Transmit	Enabled	<input checked="" type="checkbox"/>

**Economiser Backlighting Level** The Economiser Backlighting Level field selects whether economy mode affects the control head display.

Check this field to dim the display when the radio is in economy mode. If this field is unchecked, then the control head display is switched off while the radio is in economy mode. Economy mode settings are made in the [Power Saving](#) form.

If you wish the radio user to be able to change the economy mode display lighting, check the In User Menu box.

**Normal Backlighting Level** The Normal Backlighting Level field sets the control head display to either Full or Dim, during normal operation.

If you wish the radio user to be able to change the control head display lighting, check the In User Menu box.

**External Mute** The External Mute field sets whether the HUSH line on the options connector responds when the radio mute opens. This can then be used to control an external device, such as a car radio.

Check this field to activate the HUSH line when the audio mute opens.

If you wish the radio user to be able to enable and disable the external mute feature, check the In User Menu box.

**External Alert Function** The External Alert Function field sets whether the HORN line on the options connector switches an external alert device, such as a car horn.

	<p>Check this field to enable external alert. External alert settings are made in the <a href="#">Selcall Setup</a> tab.</p> <p>If you wish the radio user to be able to enable and disable the external alert feature, check the In User Menu box.</p>
Keypress Confidence Tones	<p>The Keypress Confidence Tones field enables and disables keypress confidence tones. For T2020 radios, the volume is set in the <a href="#">Keypress Confidence Tones Level</a> field.</p> <p>If you wish the radio user to be able to enable and disable keypress confidence tones from the T2020 user function menu, check the In User Menu box.</p>
Keypress Confidence Tones Level	<p>The Keypress Confidence Tones Level field sets the volume of the radio's keypress confidence tones to either High or Low. If the field <a href="#">Keypress Confidence Tones</a> is disabled, then the setting of this field has no effect.</p> <p>If you wish the radio user to be able to change the keypress confidence tones level, check the In User Menu box.</p>
Short Status Display	<p>The Short Status Display field switches the control head Selcall status message display between a status label and a status digit. If checked, the status message is displayed on the control head as a status digit only. The channel or group name is also shown, but is shortened to 6 digits. If unchecked, the status message label is shown on the control head display (e.g. "AT HOME").</p> <p>If you wish the radio user to be able to change between long and short status display, check the In User Menu box.</p>
DTMF Auto Transmit	<p>The DTMF Auto Transmit field selects the way in which the dialled DTMF string is sent. The default DTMF dialling type and other DTMF features are set in the <a href="#">DTMF</a> form. If enabled, the DTMF string is transmitted separately, as each individual key is pressed. If disabled, the DTMF string is transmitted in its entirety, once the enter key is pressed.</p> <p>If you wish the radio user to be able to change between normal and buffered DTMF dialling, check the In User Menu box.</p>
In User Menu Options	<p>The options available in the user function menu are summarised in <a href="#">Table 3</a> on <a href="#">page 63</a>.</p>

Table 3: User function menu options for T2020 radios

<b>Display</b>	<b>Settings</b>	<b>Description</b>	<b>To Add Option to Function Menu:</b>
ELIT	DIM/OFF	Sets the economy mode control head display backlighting level to either dim or off.	Check the In User Menu box for Economy Backlighting Level.
LITE	FULL/DIM	Sets the required backlighting level at power up.	Check the In User Menu box for Normal Backlighting Level.
HUSH	ON/OFF	Sets whether the HUSH line on the options connector responds when the radio mute opens.	Check the In User Menu box for External Mute.
HORN	ON/OFF	Switches the external alert function on and off.	Check the In User Menu box for External Alert.
BEEP	ON/OFF	Turns keypress confidence tones on and off.	Check the In User Menu box for Keypress Confidence Tones.
BEEP	HI/LOW	Changes the level of keypress confidence tones.	Check the In User Menu box for Keypress Confidence Tones Level.
STAT	NORM/FIX	Switches the Selcall status display between a status label and a status digit.	Check the In User Menu box for Short Status Display.
A--TX	ON/OFF	Switches the DTMF dialling type.	Check the In User Menu box for Auto Transmit.



# Part D Programming Trunked Features

This part contains detailed information on programming T2030, T2035 and T2040 radios.

## Topics

- [What's New - T2000 Trunked Radios](#)
- [Programming Trunked Radios](#)
- [Changing Network Settings](#)
- [Changing Fleet Settings](#)
- [Changing Radio Unit Settings](#)





# What's New - T2000 Trunked Radios

Key:

- N/A = Not Applicable.
- \* = not a full release.

Feature	Form	Radio Firmware Version			Database Version	
		T2030	T2035	T2040	T2030/ T2035	T2040
Hook Signalling	Data Parameters	N/A	3.53	N/A	5.05	N/A
Display Driver	Specifications	N/A	3.50*	N/A	5.04	N/A
Join Busy Group	Call Options	N/A	3.53	5.65	5.05	5.06
Single Press PTT Call	Interface Options	N/A	N/A	5.63	N/A	5.04
Auto Register at Power On	Interface Options	3.30	3.49	5.63	5.04	5.05
SOS Mute	External Calls	3.30	3.47	5.60	5.03	5.04
MPT Dynamic Regrouping	Fleet Parameters	3.27	3.44	5.55	5.03	5.04
Radio Language - Portuguese	Specifications	N/A	N/A	5.52	N/A	5.03
ECR Call Clear	External Calls	N/A	N/A	5.49	N/A	5.02
CPSX Dialling	Fleet Identity	N/A	3.44	5.46*	5.03	5.02
User Group Select	Radio Unit ID	N/A	3.44	5.46*	5.03	5.02
Site Select And Resuming Hunt	Hunting Params	N/A	3.44	5.46*	5.03	5.02

# Programming Trunked Radios

---

When programming T2030, T2035 or T2040 radios, you will find that possible entries and availability of certain features often depends upon settings in other forms. The order in which the screen data is entered is, therefore, important. See “[Programming Sequence](#)” below for more information.

Access to some programming information is restricted by the access level. See “[Changing Access Levels](#)” on page 6 for more information.

## Programming Sequence

The recommended sequence for changing radio settings is:

- network settings, then
- fleet settings, then
- radio unit settings

1. [Changing Network Settings](#)

Network data should be imported or changed first. Networks are typically set up as templates, to ensure that [network](#) settings remain consistent.

2. [Changing Fleet Settings](#)

With the network data added, add or change values to the [fleet](#) settings.

3. [Changing Radio Unit Settings](#)

After editing fleet settings, you can alter data in the other various radio unit forms.

## Working with Multiple Networks

The T2040 can operate in two completely separate trunking networks. To do this, the radio must be programmed with the parameters of both networks. Some radio unit settings are common to both networks.

You may wish to change networks because you are out of reach of the current network (the SVC indicator is flashing) or you need to have access to the second trunking network.

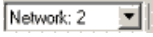
Click the  toolbar icon (or select Network > Add) to add a second network to the current database. Select File > Import to [import a network](#). Use the Network > Previous (Ctrl+J) and Network > Next (Ctrl+K), or the network combo box  to switch between the networks when entering fleet and network information.

## Setting up a network template

It is useful to have a file set up as a template to use when setting up other radio units on the same network.

1. Enter network-specific data for (Network and Fleet settings).
2. Click File > Save As...
3. Enter a descriptive name such as “Network\_Template.t2t”.
4. Click Save.

## Importing a network

T2040 radios only.

Importing a network will add another network (all the fields in the [Fleet](#) and [Network](#) settings) to the current database.



**Note:** Before importing, only one network can be currently defined to leave space for the additional network. Select Network > Delete to delete Network 2.

1. Select File > Import Network.
2. Select the “\*.t2t” file that contains the network or networks to be imported.
3. Click Open.
4. You can assign a descriptive name to the additional network using the [Network Name](#) field (Specifications form).

## Specifications (Trunked) Form

The Specifications form shows basic radio information such as the radio model and the frequency band. You can also set various radio interface options in this form, such as the power-up message, the network name and installed hardware options.

The screenshot shows the 'Specifications' form with the following fields and values:

- Radio Model Information:** Radio Model: T2040, Band: 136-174 MHz
- Network:** Network Name: NETWORK
- Installed Options:** Scrambler, Handsfree Interface, MAP27 Interface, Line Interface, Signalling Interface (all unchecked)
- Startup:** Power Up Message: TAIT T2040, Radio Language: English, Display Driver: Old
- ESN:** Chassis Serial Number: 17000000, Manufacturers Code: 4, Model Code: 2, Electronic Serial Number: 0
- Identity:** CBSN: 0

## Radio Model Information

The radio model information fields show the radio model and frequency band, which form part of the radio’s part number (e.g. T2040-523).

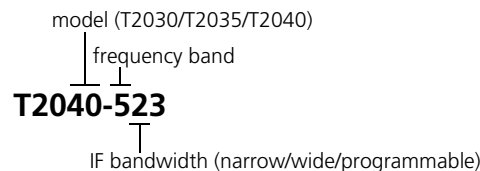

If you change the [Radio Model](#) and/or [Band](#), fields that are not relevant to the different radio band and/or radio model are automatically set to their default values.

You may wish to read data from a radio of a different type and use the settings as a template for programming radios of another variant. If so, change the values of radio model and/or radio band after loading the template file but before changing any other radio settings.

Radio Model

The Radio Model field indicates the radio’s feature set, which is indicated by the fourth and fifth positions of the radio part number.



30 indicates the [T2030](#) feature set, 35 indicates the [T2035](#) feature set and 40 indicates the [T2040](#) feature set.

The Radio Model field is set in the radio model toolbar (see [“Select a Different Radio Model” on page 5](#)). This must be set correctly as not all programmable features are available for all radio models. Changing the value of the radio model will:

- make fields relevant to the new radio model selectable, where they were previously greyed out
- grey-out fields not relevant to the new radio model

Band

The Band field sets the frequency band in which the radio operates, and is indicated by the sixth position (first after the hyphen) in the radio part number.

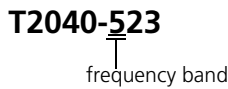

This number indicates the frequency band as follows:

Band	Frequency Range	Band	Frequency Range
0	500-530 MHz	6	450-520 MHz
1	220-270 MHz	7	330-366 MHz
2	66-88 MHz	8	800-870 MHz
3	136-174 MHz	9	360-400 MHz
4	175-225 MHz	K	896-941 MHz
5	400-470 MHz	W	300-338 MHz (T2040 radios only)



**Note:** Contact your local dealer for information on the availability of different frequency bands.

The Band field must be set correctly in order to validate channel settings, and changing the value of the radio band will set the values of the [Rx Frequency](#) and [Tx Frequency](#) fields (Conventional Channels form) to 0, as any frequency values previously entered may be invalid for the new radio band.

## Installed Options

The Installed Options fields indicate what option boards are fitted to the radio. With database version 5.01 and later two or more option boards can be fitted providing the board combinations are compatible (see Table 4). With pre 5.01 database radios when they are fitted with a MAP27 board, or a line interface board they will read back with both boards enabled. This does not affect the radio operation.



**Note:** Contact your local dealer for more information on the availability of the following option boards:

- [Scrambler](#)
- [Handsfree Interface](#)
- [MAP27 Interface](#)
- [Line Interface](#)
- [Signalling InterfaceZ](#)

Table 4: Compatibility of T2000 option boards

Option	Hands-free	MAP27 Double	MAP27 Single	Line Interface	Signalling	Scrambler
Hands-free		No	Yes	No	Yes	No
MAP27 Double	No		No	No	Yes	No
MAP27 Single	Yes	No		Yes	Yes	Yes
Line Interface	No	No	Yes		Yes	No
Signalling	Yes	Yes	Yes	Yes		No
Scrambler	No	No	Yes	No	No	
<b>Key: Yes = Compatible, No = Not Compatible.</b>						

### Scrambler

Select this option if the voice inversion scrambler module has been installed in the radio. The party you call must also have a similar scrambler. The scrambler encodes transmissions so that even if they are overheard, the voice sounds garbled.

### Handsfree Interface

Select this option if the T2000 Handsfree interface has been installed. This allows use of either a foot switch or voice (VOX) activation to automatically key the radio transmitter. The microphone can either be the normal radio mic or a remotely placed unit.

If VOX is used then the [Mode](#) (Key Settings form) must be set to Auxiliary Output and [Key Operation](#) must be set to Latching.

Enable the [Handsfree Call Initiation](#) option (Interface Options form) to call the number in the display when using a footswitch. This field should be disabled when using VOX.

MAP27 Interface	<p>Select this option if the MAP27 Interface has been installed. MAP27 (Mobile Access Protocol for MPT 1327 equipment) permits data exchange between T2000 trunked radios and 3rd party equipment such as data terminals.</p> <p>This option will enable the <a href="#">CCI Setup Form</a> and the <a href="#">Data Parameters Form</a>, where you can configure the radio to send short data messages.</p> <p>To set whether the MAP27 board is single or dual port, enable the MAP27 board, and then change the <a href="#">UIM</a> field (CCI Setup form).</p>
Line Interface	<p>Select this option if the Line Interface module has been installed in the radio. This feature allows a two wire, 600 ohm telephone line connection to directly interface with the radio's transmit and receive audio paths.</p>
Signalling Interface	<p>Select this option if the Signalling Interface has been installed. This allows the use of conventional channels and repeater systems that have CTCSS signalling as part of their operating protocol.</p>

## ESN

The fields under ESN uniquely identify the radio, and who manufactured the radio. These fields are view only.

Chassis Serial Number	This is the serial number printed on the side of the radio.
Manufacturers Code	This is the code used to represent the manufacturer of the radio.
Model Code	This is the code used to represent the model for the manufacturer of the radio.
Electronic Serial Number	This is the serial number used by the manufacturer to identify the radio.

## Network

The field in Network is [Network Name](#).

Network Name	<p>T2040 radios only.</p> <p>The Network Name field specifies the name of the selected network, which is displayed during the radio's power up sequence.</p> <p>Enter a name of up to 8 characters, selected from A-Z 0-9 * / - + &lt; &gt; \ space.</p>
--------------	--

## Startup

The startup fields enable you to configure how the radio will appear when it is first switched on.

Power Up Message	<p>T2040 radios only.</p> <p>The Power Up Message field sets the power-up message, which can be up to 24 characters. Choose from A to Z 0 to 9 * + - &lt; &gt; / \ space.</p> <p>Enter up to 12 characters, including leading spaces if you want the message to be centred.</p>
Radio Language	<p>T2040 radios only</p> <p>The Radio Language field sets the language that messages appear on the radio LCD. Select French, German, English or Portuguese.</p>

## Identity

The field in Identity is [CBSN](#).

CBSN

View only.

CBSN stands for Control Board Serial Number, which is used for identification purposes only. This field is read only and has no effect on the normal operation of the radio.

# Changing Network Settings

This part contains detailed information on changing network settings. To change the fields on these forms, you require high-level access. See [“Changing Access Levels”](#) on page 6 for more information.

## Trunked Channel Blocks Form

[Trunked channel blocks](#) specify the operating frequencies of all channels on a network. Up to 30 blocks can be defined. Select the Add button to add a new block, or select the Delete button to delete the currently selected block. At least one channel block must be defined, and so the last remaining channel block cannot be deleted.

Start Channel	Stop Channel	Start Rx Freq	Rx Spacing	Start Tx Freq	Tx Spacing	Power
1	1023	000.00000	012.50	000.00000	012.50	High

Buttons: Add, Insert, Repeat, Delete

Start Channel and Stop Channel

The Channel Start field sets the first number of each [trunked channel block](#), and the Channel Stop field sets the last channel. Enter a value from 1 to 1023 for Channel Start, and a value greater than or equal to the Channel Start value for Channel Stop. Channel Stop cannot be set higher than 1023. If more than one block is defined, the Channel Start value for all subsequent blocks must be at least one greater than the Channel Stop value for the previous block.

Start Rx Freq and Start Tx Freq

The Start Rx and Tx fields set the receive (Rx) frequency and transmit (Tx) frequency for the first channel in the [trunked channel block](#). The receive and transmit frequencies for all other channels in the block will be calculated from these values using the value of the [Rx Spacing and Tx Spacing](#) fields. For both fields, enter the values assigned by your network operator, which will be a multiple of either 5 kHz or 6.25 kHz and will be within the radio's frequency band. The first channel in a block always has the lowest frequency, and the frequency range for a block cannot overlap with any other block's frequencies.



Rx Spacing and Tx Spacing

The Rx and Tx Spacing fields sets the channel spacing (in kHz) for all channels in the [trunked channel block](#) and is the value that will be used to calculate receive and transmit frequencies from the values of the Start Rx and Start Tx fields. Enter the value assigned by your network operator, which will be a multiple of either 5 kHz or 6.25 kHz. Different blocks can have different channel spacing values.

Power

The Power field sets the transmit power level for the [trunked channel block](#). Select a power level setting (either High or Low) within the limits permitted for the region in which the radio operates.

## Network Identity Form

The fields in the Network Identity form tell the radio about the network so that the radio can communicate with it. Appropriate values for the fields in this form will be assigned by your network operator.

Network Type and NIC Code

Together the Network Type and Network Identity Code determine whether a [control channel](#) is considered an adequate candidate for [acquisition](#). If the relevant bits decoded from the control channel do not correspond to the values programmed for the radio, the radio will not consider that control channel a candidate.

The Network Type field sets the network type, which can be either National or Regional. Consult your network operator for the correct setting.

The network identity codes (NIC) set in the grid are dependent on the Network Type:

- National: Enter a code from 0 to 3.
- Regional: Enter up to 8 codes, from 0 to 127.

Enter the value assigned by your network operator.

SYNC Sequence

The SYNC Sequence field displays the bit sequence used to synchronise signalling on the channel in hexadecimal format. MPT1327 and MPT1343 define [SYNC](#) as C4D7. PAA2424 defines SYNC as B433. Consult your network operator for the correct SYNC sequence.

Area Field Length	<p>The Area Field Length field sets the value of LA, which is used in a test carried out by the radio to see if it can acquire a <a href="#">control channel</a>. The value depends on whether Network Type is National or Regional. In <a href="#">MPT 1327</a>, if the Network Type is National enter a value from 0 to 9. If the Network Type is Regional enter a value from 0 to 4.</p> <p>Consult your network operator for the correct field length value.</p>
Zone Field Length	<p>The Zone Field Length field sets the value of LZ, which is used in a test carried out by the radio to see if it can acquire a <a href="#">control channel</a>. The value depends on whether Network Type is National or Regional. In <a href="#">MPT1327</a>, if the Network Type is National enter a value from 0 to 9. If the Network Type is Regional enter a value from 0 to 4.</p> <p>Consult your network operator for the correct field length value.</p>
SIL Field Length	<p>The SIL Field Length field is used in a test by the radio to check whether the clear down message received is from the correct TSC (<a href="#">trunking system controller</a>). Consult your network operator for the correct field length value.</p>
Pressel On Messages	<p>The Pressel On Messages field determines how many Pressel On Messages are sent to the system when the PTT is pressed during a speech call. Enter a value from 1 to 5. Obtain the correct value from your network operator.</p>
Pressel Off Messages	<p>The Pressel Off Messages field determines how many Pressel Off Messages are sent to the system when the PTT is released during a speech call. Enter a value from 1 to 5. Obtain the correct value from your network operator.</p>
Multiple Registration	<p>The Multiple Registration field determines whether the radio can register simultaneously on up to three <a href="#">control channels</a>.</p> <p>Checked: The radio can store up to three <a href="#">registration</a> records and thereby be simultaneously registered on up to three control channels. It can then roam between those control channels and acquire any of them without re-registering. The oldest registration records expire and are deleted after a period <a href="#">TD</a> following registration (<a href="#">Network Parameters Form</a>). The most recent record is known as the Prime record and does not expire. The trunking system announces how many registration records (either 1, 2 or 3) a radio shall maintain, via the BCAST SYSDEF 3 message.</p> <p>Unchecked: Only a single registration record is maintained and any previous registration record will be discarded when the radio registers on a control channel.</p>
Transmit Slot Timing	<p>The Transmit Slot Timing field controls the time relative to the start of the <a href="#">control channel</a> slot when a synchronous codeword is transmitted. There are 2 options:</p> <p>MPT: the slot timing conforms to <a href="#">MPT1327</a> section 6.2.</p> <p>Tait: the preamble is shortened by 4ms which results in the codeword transmission being advanced by approximately 5 bits. Only select this option if early codeword transmission is required.</p>
Value Of INFO In RQR	<p>The Value of INFO in RQR field defines a 15 bit value which is added to the INFO field when a radio requests registration.</p>

This INFO value can be used to convey additional information to the [trunking system controller \(TSC\)](#). This is usually set to 0. If the [Dialling Scheme \(Fleet Identity form\)](#) is [Nokia ANN](#), set this value to 16. Consult your network operator if in any doubt.

## Network Parameters Form

The fields in the Network Parameters form set variables used in communicating with the trunking system [control channel](#).

The screenshot shows a 'Network Params' window with three main sections:

- Control Channel Acquisition/Retention:**
  - Continuous: NZ1 (1), NZ2 (3), TS (5), NC1 (20), NC2 (15), NV (1), NX1 (15), NX2 (10)
  - Time-shared: (6), (54), (1), (2), (3)
- Background Hunt Parameters:**
  - TL (min): 2, TL (sec): 0
  - TH: 10, LM1: 10
  - NS: 2, LM2: 10, LM3: 10
- Signalling Parameters:**
  - NT: 103, TJ: 60
  - NW: 4, TN: 7
  - ND1: 3, TT: 60
  - ND2: 5, TA: 60
  - NE: 16, TB: 2
  - NR: 8, TP: 5
  - NI: 4, TW: 60
  - TC: 60, TI: 2
  - TD: 60

### Control Channel Acquisition/Retention

The fields listed under Continuous and Time-Shared parameters set parameters the radio uses when attempting to acquire and retain a continuous or time-shared [control channel](#).

- NZ1 NZ1 sets the number of contiguous error check samples containing no error events. Enter a value from 1 to 255.
- NZ2 NZ2 sets the number of contiguous error check samples each generating a codeword error event following an initial error event. Enter a value from 1 to 255.
- TS TS sets the delay before leaving a control channel. Enter a value from 1 to 10 seconds.
- NC1, NC2, NX1, NX2 The combination of parameters NC and NX set the error threshold at which the [control channel](#) performance is considered inadequate. Separate values of NC and NX are set for use during hunting (NC1 and NX1) and during continuous monitoring of a confirmed control channel (NC2 and NX2).  
Parameters NC1 and NC2 are the number of contiguous positions in which [codewords](#) are expected that will be monitored in each codeword.  
Parameters NX1 and NX2 are the number of errored codewords that must be exceeded in the count of the respective NC codewords before the sample of NC codewords is considered an error event.

NC1, NC2: Set a value from 1 to 255 for both continuous and time-shared channels.

NX1: Set a value from 0 to the value of the corresponding NC1 parameter for continuous and time-shared channels.

NX2: Set a value from 0 to the value of the corresponding NC2 parameter for continuous and time-shared channels.

NV Parameter NV sets the number of consecutive CCSCs ([codewords](#)) with the same value of SYS field that must be received before the radio will attempt to verify that value.

Enter a value from 1 to 16 for both continuous and time-shared channels.

## Signalling Parameters

The fields listed under Signalling parameters set various parameters used in communication with the [control channel](#).

NT NT sets the maximum [trunking system controller](#) (TSC) response delay to unsolicited traffic channel messages. Enter a value from 103 to 1236 in steps of 103.

NW NW sets the response delay (in slots). Enter a value from 1 to 15.

ND1 ND1 sets the number of disconnect messages sent by an individually called radio unit. Enter a value from 1 to 5.

ND2 ND2 sets the number of disconnect messages sent by a calling radio. Enter a value from 1 to 5.

NE NE determines the maximum number of random access transmissions of RQE (emergency call request). Enter a value from 1 to 255.

NR NR determines the maximum number of random access transmission of RQS, RQD, RQX, RQT, RQR or RQQ (non-emergency call requests). Enter a value from 1 to 255.

NI NI sets the maximum number of include request access attempts. Enter a value from 1 to 255.

TC TC sets the random access timeout. Enter a value from 10 to 120 seconds, in steps of 10.

TD TD sets the [registration](#) record timeout used when [Multiple Registration](#) (Network Identity screen) is enabled. Enter a value from 5 to 70 minutes, in steps of 5.

TJ TJ sets the further signalling timeout. Enter a value from 10 to 60 seconds, in steps of 10.

TN TN sets the [traffic channel](#) inactivity timeout. Enter a value from 1 to 10 seconds.

TT TT sets the maximum transmit duration. Enter a value from 10 to 60 seconds, in steps of 10.

TA	TA sets the timeout for the radio unit after receiving an AHY. Enter a value from 1 to 255 seconds.
TB	TB determines the time barred from calling the same ident after ACK (general acknowledgement), ACKX (message rejected), ACKV (called unit unavailable) or any ident after an ACKT (try on given address) or ACKB (call back, negative ack). Enter a value from 1 to 255 seconds.
TP	TP determines the maximum interval between periodic messages (within speech limits) to be assumed at switch-on. Enter a value from 1 to 255 seconds.
TW	TW sets the timeout for the radio unit waiting for a call. Enter a value from 1 to 255 seconds.
TI	TI sets the include timer. This sets the maximum time to wait for a response to an include request. Enter a value from 1 to 255 seconds.

### Background Hunt Parameters

The fields listed under Background Hunt Parameters set parameters the radio uses when carrying out a background search. The [Background Hunt](#) field ([Hunting Parameters Form](#)) must be enabled for these parameters to have effect.

TL (min) and TL (sec)	TL specifies how long the radio will spend on an acquired <a href="#">control channel</a> before leaving to begin a <a href="#">background hunt</a> . Enter a time between 0 min 10 sec and 30 min 0 sec. This value is network dependent.
TH	TH specifies how long the radio will spend on each timed sampling activity in the <a href="#">background hunt</a> , before returning to the acquired channel. Enter a number of slots between 1 and 99. This value is network dependent.
NS	NS specifies how many timed sampling activities must return qualifying signal strength readings for a channel before the radio will identify that channel as a prospective new <a href="#">control channel</a> . Enter a number between 1 and 10.
LM1, LM2 and LM3	<p>A sampled channel must exceed the confirmed channel's signal strength by one of these margins in order to become a prospective <a href="#">control channel</a>. Enter values between 0 and 40dB.</p> <ul style="list-style-type: none"> <li>■ LM1: margin effective when neither the confirmed channel or the sampled channel have preferential status.</li> <li>■ LM2: margin effective when both the confirmed and sampled channels have preferential status.</li> <li>■ LM3: margin effective when the confirmed channel does not have preferential status, but the sampled channel does.</li> </ul> <p>These values are network dependent.</p>

### Hunting Parameters Form

The fields in the Hunting Parameters form relate to network [hunts](#) carried out by the radio. If the radio fails to find a suitable control channel among these channels, it will search through all channels if the [Comprehensive Hunt](#) field is enabled.

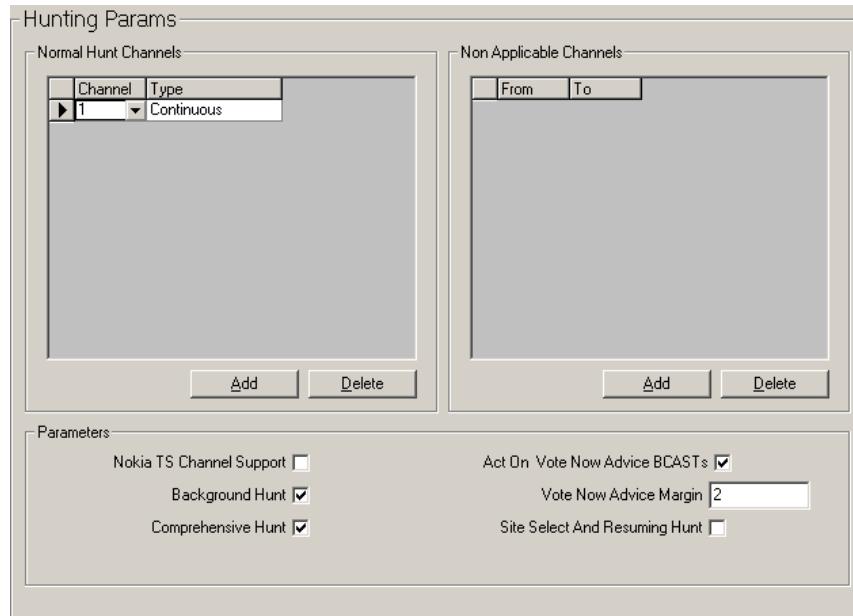

### Normal Hunt Channels Grid

The Normal Hunt Channels grid defines the channels that will be examined during a normal background search sequence to see if they can be acquired as a [control channel](#). The channels available to the radio are defined in the [Trunked Channel Blocks Form](#).

Up to 32 normal hunt channels can be defined. At least one channel must be defined, and so the last remaining channel cannot be deleted.

**Channel** For the Channel field, enter any channel number between the lowest and highest channel defined for the network. See your network operator for these values.

**Type** For the Type field, select Continuous or Time-shared. See your network operator for the channel type. This is usually Continuous.

### Non Applicable Channels Grid

The Non Applicable Channels grid defines the upper and lower limits of the channel range that will not be included in comprehensive hunt sequences. Select the Add button to add a new range of channels, or select the Delete button to delete the currently selected range.

You can define up to ten channel ranges, where the [From](#) field defines the start of the range not included in the [hunt](#) and the [To](#) field defines the end of the range not included in the hunt. See your network operator for these values.

If [Comprehensive Hunt](#) is disabled or if you do not wish to limit the range of channels the radio will search, this list can be left blank.

**From** The From field defines the start of channel range not included in [comprehensive hunt](#) sequences.

**To** The To field defines the end of channel range not included in [comprehensive hunt](#) sequences.

## Parameters

The fields under Parameters define additional [hunting](#) features.

Nokia TS Channel Support	<p>Nokia TS Channel Support enables the radio to recognise Nokia time-shared control channels. This significantly improves background hunting performance on time-shared channels.</p> <p>If Nokia TS Channel Support is enabled, the radio will no longer be compliant with <a href="#">MPT 1343</a>.</p>
Background Hunt	<p>Background hunt is a method prescribed in MPT 1343 for monitoring other <a href="#">control channels</a> and migrating to a superior channel when one is found.</p> <p>The search is performed by periodically leaving the current control channel and sampling other control channels. What channels are sampled is defined in the <a href="#">Normal Hunt Channels Grid</a>. If a channel is consistently found for a certain number of consecutive samples to be preferred (according to the NDD preference data defined in the <a href="#">Acquisition Data Form</a>) or stronger than the current control channel by a certain margin, the radio acquires the new control channel.</p> <p>Enable the Background Hunt field to allow the radio to carry out <a href="#">background searches</a>.</p> <p>Advanced settings also influence background hunts. See “<a href="#">Background Hunt Parameters</a>” on page 79.</p>
Comprehensive Hunt	<p>Comprehensive Hunt determines whether a <a href="#">comprehensive hunt</a> is carried out if a <a href="#">normal hunt</a> fails to acquire a <a href="#">control channel</a>. This will search through all channels in the trunked channel blocks defined for the radio, rather than just those specified in the <a href="#">Normal Hunt Channels Grid</a>.</p>
Act On Vote Now Advice BCASTs	<p>Some trunking systems use the <a href="#">vote now</a> advice BCAST codeword to help radios find the best <a href="#">control channel</a>.</p> <p>Enable this field to take advantage of this feature.</p>
Vote Now Advice Margin	<p>A channel sending a Vote Now Advice BCAST must exceed the current control channel’s signal strength by this margin at the radio before being acquired as the new <a href="#">control channel</a>. Enter a value between 1 and 15dB.</p>
Site Select And Resuming Hunt	<p>The <a href="#">site select</a> feature allows a user to select a <a href="#">control channel</a> to which the radio must adhere and attempt to register on without continuing any other hunt process.</p> <p>This is available for <a href="#">T2035</a> radios using the Queue key, or <a href="#">T2040</a> radios using the Enter key.</p>

## ANN Interfleet Form

The ANN Interfleet form contains details of other fleets that the radio is able to call when [Interfleet Calls](#) or [Interfleet Group Calls](#) (Call Options form) are disabled and the [Dialling Scheme](#) (Fleet Identity form) is [Nokia ANN](#).

You can enter up to 8 interfleet numbers. Each number entered must be a valid Nokia ANN interfleet number with the correct number of digits for the selected ANN Numbering Model. The radio user may then call any party within the group or individual fleet to which the entered interfleet number belongs. Before any numbers are entered, the [Fleet Structure Definition](#) and [ANN Numbering Model](#) must have been entered on the Fleet Identity form.

The screenshot shows a window titled "ANN Interfleet" containing a table with four columns: "ANN Lead", "ANN Prefix", "ANN Fleet", and "ANN Unit ID". Below the table are two buttons labeled "Add" and "Delete".

ANN Lead	ANN Prefix	ANN Fleet	ANN Unit ID

- ANN Lead                    The ANN Lead field is the start of the ANN number. This will be 7 for units that belong to large and small fleets, or 7, 8 or 9 for units that belong to mini fleets.
  
- ANN Prefix                Enter the prefix of the ANN unit number. This will be a 1 digit number if the [ANN Numbering Model](#) (Fleet Identity form) is Medium, a 2 digit number if the numbering model is Large, and a number between 00 and 99 or 100 and 127 if the numbering model is Extra Large. This field will be greyed out if the numbering model is Small.
  
- ANN Fleet                 Enter the fleet number of the ANN unit number. This will be a 2 digit number for small and mini fleets, and a 1 digit number for large fleets.
  
- ANN Unit ID              Enter the individual unit number. This will be a 2 digit number for small and mini fleets, and a 3 digit number for large fleets.



# Changing Fleet Settings

This part contains detailed information on changing fleet settings. To change the fields on these forms, you will require at least medium-level access. See “[Changing Access Levels](#)” on page 6 for more information. The [Dialling Scheme](#) selected also changes which fields you can or cannot access.

## Fleet Identity Form

The fields in the Fleet Identity form provide information about the fleet to which a radio unit belongs. These properties are generally common to all radios in a fleet.

Prefix Start	Prefix Stop	FPP	MEP	Large	Medium	Small
--------------	-------------	-----	-----	-------	--------	-------

### Dialling Scheme

The Dialling Scheme field describes the dialled digit sequence categories used by the radio for interfleet and intrafleet calls. The dialling scheme is system-dependent and so must be used only with compatible trunking systems. T2000 radios support five options.

- **MPT 1343**: Suitable for all MPT 1343 networks.
- **ZVEI**: Suitable for Regionet 43 networks.
- **Number Presets**: Suitable for all MPT 1343 networks. However, dialling will be limited to the preset calls programmed for the radio (in the Preset Calls form).
- **Nokia ANN**: Suitable for all Nokia Actionet networks.
- **CPSX dialling**: Suitable for Chinese networks that utilise 5-digit interfleet dialling. It is compatible only with other CPSX dialling trunking systems.

Consult your network operator for the appropriate Dialling Scheme.

### Settings

The fields in Settings define the numbering of the fleet that the radio belongs to.

Fleet Num Prefix	Fleet Num Prefix is an MPT1343 value which must be common to all units in a fleet. This prefix forms part of the address of individual radios. Enter an assigned value from 200 to 327.
Fleet Individual Num	Fleet Individual Num is used to calculate the individual base identity for a fleet. This value is used with the <a href="#">Radio Unit ID</a> and <a href="#">Fleet Num Prefix</a> to uniquely identify the unit within the system. Enter a number between 2001 and 6050.
Fleet High Individual Num	Fleet High Individual Num defines the highest individual number that may be called by any unit within a fleet. It is assigned by the network operator. If the <a href="#">Dialling Scheme</a> is ZVEI then this value must be between 20 and 79 or 200 and 799. For any other dialling scheme, this field will accept a value between 20 and 89 or 200 and 899. The value of <a href="#">Fleet Individual Num</a> may reduce the upper value in these ranges.
Fleet Group Num	The Fleet Group Num field is used with the group memberships defined in the <a href="#">Group Membership Grid</a> (Radio Identity form) to identify groups of radios in a network. Enter the value assigned by your network operator, which will be from 2001 to 6050. If the user is not allowed group calls, enter 0.
Fleet High Group Num	The Fleet High Group Num field defines the highest group number that can be called by any unit within a fleet. If the <a href="#">Dialling Scheme</a> is ZVEI then this value must be between 90 and 99 or 200 – 299 900 and 999. For any other dialling scheme, this field will accept a value between 90 and 99 or 900 and 998. The value of <a href="#">Fleet Individual Num</a> may reduce the upper value in these ranges. If the value of Fleet Group Number is 0, then this field should also be set to 0.

### Fleet Structure Definition

The Fleet Structure Definition grid defines the Nokia ANN or CPSX (Algorithmic Network Numbering) fleet structure, which differs from MPT 1343 numbering in the way it divides fleets.

Up to 128 blocks can be defined. Select the Add button to add a new block, or select the Delete button to delete the currently selected block. For each block, you must set: Start Prefix, Stop Prefix, FPP and MEP.

ANN Numbering Model	<p>Nokia ANN dialling scheme only.</p> <p>The ANN Numbering Model field defines the length of strings to be used for interfleet numbers. Select either Small, Medium, Large or Extended Large.</p> <ul style="list-style-type: none"> <li>■ Small: Interfleet numbers contain 5 digits and fleets with prefix 0 are accessible.</li> <li>■ Medium: Interfleet numbers contain 6 digits and fleets with prefixes from 0 to 9 are accessible.</li> <li>■ Large: Interfleet numbers contain 7 digits and fleets with prefixes from 0 to 99 are accessible.</li> <li>■ Extended Large: Interfleet numbers contain either 7 or 8 digits. Fleets with prefixes from 0 to 127 are accessible, although in some cases dialling may be abbreviated to 7 digits.</li> </ul>
Prefix Start	The first prefix of the range to which the values given for <a href="#">FPP</a> and <a href="#">MEP</a> (Nokia ANN dialling scheme) or <a href="#">Large, Medium and Small</a> (CPSX dialling scheme) apply. For Nokia ANN, the range of numbers available for this field depends on the <a href="#">ANN Numbering Model</a> selected.

	This number is assigned by the network operator.
Prefix Stop	<p>The last prefix of the range to which the values given for <a href="#">FPP</a> and <a href="#">MEP</a> (Nokia ANN dialling scheme) or <a href="#">Large, Medium and Small</a> (CPSX dialling scheme) apply. For Nokia ANN, the range of numbers available for this field depends on the <a href="#">ANN Numbering Model</a> selected.</p> <p>This number is assigned by the network operator.</p>
FPP	<p>Nokia ANN dialling scheme only.</p> <p>FPP (Fleet Partitioning Parameter) is used with MEP to define the fleet structure of a Prefix range. Enter a value between 0 and 10.</p> <p>This number is assigned by the network operator.</p>
MEP	<p>Nokia ANN dialling scheme only.</p> <p>MEP (the Miniaturisation Extent Parameter) is used with FPP to define the fleet structure of a Prefix range. Enter a value between 0 and 10.</p> <p>This number is assigned by the network operator.</p>
Large, Medium and Small	<p>CPSX dialling scheme only.</p> <p>How many large, medium, small and tiny fleets there are is determined by the values of the parameters Large, Medium and Small.</p> <p>Using these parameters, the network operator can configure a system in which interfleet and interprefix dialling are possible from any radio in any other fleet of any other prefix. Interfleet calls are made by dialling a five-digit number, and interprefix calls are made by dialling an eight-digit number.</p> <p>Because each type of fleet is fixed in size, the values of the fields in the <a href="#">Fleet Structure Defintion</a> grid will determine the values of <a href="#">Individual Call Min and Max</a> and <a href="#">Group Call Min and Max</a> fields (Radio Identity form) and <a href="#">Fleet High Individual Num</a> and <a href="#">Fleet High Group Num</a> fields (Fleet Identity form).</p> <p>See “<a href="#">CPSX Dialling</a>” on <a href="#">page 123</a> for more information.</p>

## Fleet Parameters Form

The fields in the Fleet Parameters form define how calls are controlled.

The screenshot shows a 'Fleet Parameters' form with the following sections and fields:

- Dispatcher:** Prime Despatcher Number (text input, value: 0)
- Emergency:** Prime Emergency Number (text input, value: 0), Prime Emergency Address Prefix (text input, value: 0), Prime Emergency Address Ident (text input, value: 0)
- Features:** Full Off Air Call Setup (checkbox, unchecked), Call Timer Count Up (checkbox, checked)
- Default Call Time Limit:** Enable (checkbox, checked), Time (text input, value: 60)
- Emergency Call Time Limit:** Enable (checkbox, checked), Time (text input, value: 600)
- Parameters:** Data Call Time Limit (text input, value: 60), Ignore TSC Call Time Limit (checkbox, unchecked)

Prime Despatcher Number	The Prime Despatcher Number defines the number which the mobile calls when a despatcher call (* 0) is dialled without specifying a unit number. For fleets without a despatcher, enter 0.
Prime Emergency Number	The Prime Emergency Number defines the number the mobile calls when an emergency call (* 9) is dialled without specifying a radio number. Enter a valid unit number within the radio's own fleet. If the prime emergency address is not a valid unit number within the radio's own fleet, then the number may be entered in MPT1327 format using the <a href="#">Prime Emergency Address Prefix</a> and <a href="#">Prime Emergency Address Ident</a> fields. In this case, enter 0 here. Disable the prime emergency address by setting this field to 0.
Prime Emergency Address Prefix	Prime Emergency Address Prefix specifies the prefix in the MPT1327 prefix/ident format. Enter a value between 0 and 127.
Prime Emergency Address Ident	Prime Emergency Address Ident specifies the ident in the MPT1327 prefix/ident format. Enter a value between 1 and 8100.
Full Off Air Call Setup	Some systems can seek acknowledgement from the called party before setting up a call. This field specifies whether such acknowledgement is required. If checked, an acknowledgement is sought from the called party. If unchecked, calls are set up without acknowledgement from the called party.
Call Timer Count Up	If Call Timer Count Up is checked, and <a href="#">Default Call Time Limit</a> is set to 0, the radio displays the current call time length.
Default Call Time Limit	Default Call Time Limit defines the maximum time that a call may be set up for. In MPT1327, this value can be overwritten by a BROADCAST message from the system. If the Enable field is not checked, there will be no limit on call time. To enter a time limit on calls, select Enable, and enter a time between 10 and 254 seconds in steps of 1 or 300 to 780 seconds in steps of 60.

Emergency Call Time Limit	Emergency Call Time Limit defines the maximum time that an emergency call may be set up for. If the Enable field is not checked, there will be no limit on call time. To enter a time limit on emergency calls, select Enable and enter a time between 10 and 254 seconds in steps of 1 or 300 to 780 seconds in steps of 60.
Data Call Time Limit	Data Call Time Limit defines the maximum time that a data call may be set up for. Enter any value between 30 and 180 in steps of 30 seconds, or 0 for unlimited data call time.
Ignore TSC Call Time Limit	If Ignore TSC Call Time Limit is checked, the radio ignores the network's call time limit and counts down using the <a href="#">Default Call Time Limit</a> as programmed.

## Conventional Channels (Trunked) Form

A trunked radio can switch between trunked and conventional modes of operation. You can define up to ten conventional channels for T2040 radios, and four channels for T2030 and T2035 radios in the Conventional Channels form.

Access Num	Rx Frequency	Tx Frequency	Power	Signalling
▶ 101	000.00000	000.00000	High	Off

Options:

Hookswitch Monitor       Access Conv Channels

Tx Inhibit On Busy

Access Num	Access Num defines the string that will change the unit to a predefined channel. For T2030 or T2035 radios, enter a value from 101 to 104. You will need to define this Access Number as a preset on the <a href="#">Preset Calls Form</a> . For T2040 radios, enter a value from 101 to 110. The Access Number can be entered from the front panel of the T2040, so define it as a preset only if specifically required.
Rx Frequency	RX Frequency defines the receive frequency for the conventional channel. Enter a frequency between the upper and lower frequency limits defined in the Specifications form > <a href="#">Band</a> field. For 100 to 700MHz radios, enter a multiple of either 5kHz or 6.25kHz. For 800MHz radios, enter a multiple of 12.5kHz.

Tx Frequency	TX Frequency defines the transmit frequency for the conventional channel. Enter a frequency between the upper and lower frequency limits defined in the Specifications form > <a href="#">Band</a> field. For 100 to 700MHz radios, enter a multiple of either 5kHz or 6.25kHz. For 800MHz radios, enter a multiple of 12.5kHz.
Power	The Power field sets the transmit power level for the conventional channel. Select a power level setting (either High or Low) within the limits permitted for the region in which the radio operates.
Signalling	Signalling defines the <a href="#">Signalling Interface</a> . This requires an option board to be fitted and is enabled when the channel is selected. Set to On or Off.
Hookswitch Monitor	When the Hookswitch Monitor field is checked, the <a href="#">monitor</a> is activated when the <a href="#">hookswitch</a> is open.
Tx Inhibit On Busy	If TX Inhibit on Busy is checked, the radio will not transmit when the PTT is pressed and there is activity on a channel.
Access Conv Channels	The Access Conv Channels field determines whether the radio can operate in conventional mode. This field is read only, and enabled by default to allow the radio to operate on the conventional channels defined in the Conventional Channels grid.

# Changing Radio Unit Settings

This part contains detailed information on changing radio unit settings, radio calls and radio customisation. To change the fields on these forms, you will require at least low-level access. See “[Changing Access Levels](#)” on page 6 for more information.

## Radio Unit ID Form

The fields in the Radio Unit ID form set the individual and group addresses for the radio, and help identify the radio on the network.

Num	Prefix	Ident	Lead	Prefix	Fleet	ID	Group Attributes
0	0	0	7		00	90	Permanent

### Identity

The fields under Identity define the radio’s unique identifying number.

#### Radio Unit ID

The Radio Unit ID field sets the MPT1343 number which uniquely identifies this radio within its fleet. If the [Fleet High Individual Num \(Fleet Identity Form\)](#) is a 2 digit number, enter a value between 20 and the Highest Individual Number in Fleet. If the [Fleet High Individual Num](#) field is a 3 digit number, then enter a value between 200 and the Highest Individual Number in Fleet.

#### Nokia

The Nokia field sets the ANN Group Number which uniquely identifies this radio within its fleet. This field is only available when the [Dialling Scheme \(Fleet Identity form\)](#) is Nokia ANN.

- 1st box: The start of the ANN number. This will be 7 for units that belong to large and small fleets, or 7, 8 or 9 for units that belong to mini fleets.
- 2nd box: The prefix of the ANN unit number. This will be a 1 digit number if the [ANN Numbering Model \(Fleet Identity form\)](#) is Medium, a 2 digit number if the numbering model is Large, and a number between 00 and 99 or 100 and 127 if the numbering model is Extra Large. This field will be greyed out if the numbering model is Small.
- 3rd box: The fleet number of the ANN unit number. This will be a 2 digit number for small and mini fleets, and a 1 digit number for large fleets.

- 4th box: The individual unit number. This will be a 2 digit number for small and mini fleets, and a 3 digit number for large fleets.

## Group Membership Grid

The Group Membership grid defines what groups the radio belongs to. A radio can belong to up to 4 groups (T2030 radios) or 32 groups (T2035 and T2040 radios). Select the Add button to add a new group address, select the Delete button to delete the currently selected group address, or select the Repeat button to duplicate the current group address' settings.

How group addresses are entered depends on the [Dialling Scheme](#) (Fleet Identity form).

- If the dialling scheme is [MPT 1343](#), [ZVEI](#) or [Number Presets](#), group addresses can be entered in MPT 1343 format (in the [Number](#) field) or in MPT 1327 format (in the [Prefix and Ident](#) fields). For MPT 1343 format, the numbers entered are dependent on the [Fleet High Group Num](#) field (Fleet Identity form). If Fleet High Group Num has two digits, enter a value from 90 to the Fleet High Group Num. If Fleet High Group Num has three digits, enter a value from 900 to Fleet High Group Num. For MPT 1327 format, enter a Prefix from 0 to 127 and an Ident from 1 to 8100.
- If the dialling scheme is CPSX Dialling, enter a group number (in the [Number](#) field) within the range specified by [Group Call Min and Max](#). If the group is in a different fleet, enter the full interfleet dialling number.
- If the dialling scheme is [Nokia ANN](#), group addresses must be entered in the Lead, Prefix, Fleet and ID fields.

Number	<p>MPT1343, ZVEI, Number Presets, CPSX dialling schemes only.</p> <p>Group addresses may be entered in MPT1343 or CPSX (number) or MPT1327 (Prefix/Ident) format. If you enter a value in one of these formats, the other must be left blank.</p> <p>The value in the Number field is dependant on the <a href="#">Fleet High Group Num</a> field in the <a href="#">Fleet Identity Form</a>.</p> <ul style="list-style-type: none"> <li>■ If Fleet High Group Num has two digits, this value must be between 90 and Fleet High Group Num.</li> <li>■ If Fleet High Group Num has three digits, this value must be between 900 and Fleet High Group Num.</li> </ul> <p>Enter 0 if you do not require a group number, or if you intend to specify a group address in MPT1327 format.</p>
Prefix and Ident	<p>MPT1327 number format only.</p> <p>Enter a Prefix (from 0 to 127) and an Ident (from 1 to 8100). If you do not require a group address in this format, enter 0 in both fields.</p>
Lead	<p>Nokia ANN dialling scheme only.</p> <p>Lead is the start of the Nokia ANN number. This will be 7 for groups that belong to large and small fleets, or 7, 8 or 9 for groups that belong to mini fleets.</p>
Prefix	<p>Nokia ANN dialling scheme only.</p>



Prefix is the Nokia ANN Prefix number. This will be a 1 digit number if the [ANN Numbering Model](#) (Fleet Identity form) is Medium, a 2 digit number if the numbering model is Large, and a number between 00 and 99 or 100 and 127 if the numbering model is Extra Large. This field will be greyed out if the numbering model is Small.

Fleet	<p>Nokia ANN dialling scheme only.</p> <p>Fleet is the Nokia ANN fleet number. This will be a 2 digit number for small and mini fleets, and a 1 digit number for large fleets.</p>
ID	<p>Nokia ANN dialling scheme only.</p> <p>ID is the Nokia ANN group number. This will be a 2 digit number for small and mini fleets, and a 3 digit number for large fleets.</p>
Group Attributes	<p>This gives the attribute of the group. The options available depend on the setting of the <a href="#">User Group Select</a> field.</p> <p>If User Group Select is unchecked, only Permanent is available and the user cannot select the group from the front panel.</p> <p>If User Group Select is checked, select Permanent, Selectable, Scan+Selectable or Scan.</p> <ul style="list-style-type: none"><li>■ Permanent - the group is permanently enabled.</li><li>■ Selectable - the user can select the group individually.</li><li>■ Selectable + Scan - the group can be accessed individually, and is also added to the block of scan groups, which appears as '----' on T2035 radios and '***' on T2040 radios.</li><li>■ Scan - the group is added to the block of scan groups, which appears as '----' on T2035 radios and '***' on T2040 radios.</li></ul>
User Group Select	<p>If the User Group Select Feature is enabled, and groups are set to Selectable or Scan in the <a href="#">Group Attributes</a> field, then a user can select a group or group of groups (scan group) from the mobile. User Group Select is accessed using a long press of the alphanumeric key (T2040 radios) or queue key (T2035 radios) from the front panel.</p>

## Restrict Calls

The fields under Restrict Calls restrict the calls that the radio can make to a defined number range.

Individual Call Min and Max	<p>Individual Call Min and Max define the range of individual numbers a radio can call. The setting of these fields can restrict the calls a radio can make to other radios in the fleet. The range entered is dependent on the <a href="#">Fleet High Individual Num</a> field in the <a href="#">Fleet Identity Form</a>.</p> <ul style="list-style-type: none"><li>■ If Fleet High Individual Num has two digits, the number range for Individual Call Min and Max can be anywhere from 20 to Fleet High Individual Num.</li><li>■ If Fleet High Individual Num has three digits, the number range for Individual Call Min and Max can be anywhere from 200 to Fleet High Individual Num.</li></ul> <p>If you wish to prevent the radio from making individual calls to other radios in its fleet, enter 0 in both fields.</p>
-----------------------------	---

Group Call Min and Max

Group Call Min and Max define the range of group numbers a radio can call. The setting of these fields can restrict the calls a radio can make to groups of radios in the fleet. The range entered is dependent on the [Fleet High Group Num](#) field in the [Fleet Identity Form](#).

- If Fleet High Group Num has two digits, the Number Range for Group Calls can be anywhere from 90 to Fleet High Group Num.
- If Fleet High Group Num has three digits, the Number Range for Group Calls can be anywhere from 900 to Fleet High Group Num.

If you wish to prevent the radio from making group calls to other radios in its fleet, enter 0 in both fields.

## Settings

The field under Settings is [Control Category](#).

Control Category

The Control Category field governs the radio's rights of access to the control channels on a network. A radio can only access a control channel when it agrees with the value of the LAB field in the system identity code. Select one of the categories A, B, C, or D.

## Acquisition Data Form

The grids in the Acquisition Data form define data used when the radio is attempting to acquire a [control channel](#).

The screenshot shows the 'Acquisition Data' form with three main sections:

- Acquisition Authorisation:** A table with columns 'Type' and 'Code'. The 'Type' dropdown is set to 'Full' and the 'Code' field contains '0'. Below the table are 'Add', 'Repeat', and 'Delete' buttons.
- NDD Preference Data:** A table with columns 'Field Length', 'Priority', and 'Value'. The 'Field Length' dropdown is set to '1', 'Priority' is '10', and 'Value' is '1'. Below the table are 'Add', 'Repeat', and 'Delete' buttons.
- Zones:** A section with a 'Home Zone' label and a text input field containing '0'.

### Acquisition Authorisation Grid

The fields in the Acquisition Authorisation grid specify how the radio identifies a control channel on which it can operate. Up to eight definitions are permitted. Select the Add button to add a new definition, select the Delete button to delete the currently selected definition, or select the Repeat button to duplicate the current definition's settings.

Type

The Type field specifies the areas of the trunking network in which the radio may operate. Enter the value assigned by your network operator, which will be Full, Area or Zone.

Code The Code field sets the specific code for acquisition authorisation. On some networks, this field is left blank. Possible entries are constrained by the values of the fields [Area Field Length](#) and [Zone Field Length](#) (Network Identity form). If the [Network Type](#) (Network Identity form) is National, enter a value from 0 to 511. If the Network Type is Regional, set a value from 0 to 15.

### **NDD Preference Data Grid**

The fields in the NDD Preference Data grid define the information used to encourage the radio to acquire certain control channels during a [preferential hunt](#). Up to four definitions are permitted. Select the Add button to add a new definition, select the Delete button to delete the currently selected definition, or select the Repeat button to duplicate the current definition's settings. For each definition, you must specify Field Length, Priority and Value.

Field Length The Field Length field specifies how many bits of the SYS code are used to determine the identity of the site to be allocated a priority. The maximum number is dependent on the [Network Type](#) (Network Identity form).  
If the Network Type is National, enter a value from 1 to 9 for Field Length. If the Network Type is Regional, enter a value from 1 to 4 for Field Length.

Priority The Priority field specifies the priority of the entry, from 1 (high) to 10.

Value The Value field specifies the decimal value of the binary bits derived from the SYS code to determine the site to be given priority. Value must be storable in the number of bits specified by [Field Length](#).

### **Zones**

The field under Zones is [Home Zone](#).

Home Zone The Home Zone field specifies the network zone in which the radio is normally working. The radio also uses the home zone to determine whether re-registration is required on a network when [registration](#) records for the network have only been maintained on a temporary basis.

The maximum value of Home Zone depends on the value of [Zone Field Length](#) (Network Identity form).

## CCI Setup (Trunked) Form

The CCI (Computer Controlled Interface) Setup form allows the radio to communicate with a PC, to allow remote control of the radio and data transmission. For this form to be enabled, the [MAP27 Interface](#) must be installed and selected (Specifications Form).



**Note:** CCI is also referred to as UIM (UART Interface Module).

The requirements for many of the settings on this page are variable, depending on the type of device the UIM must communicate with.

The Port B option in the UIM Setup screen is disabled (grey) and cannot be used if Single has been selected in the [UIM](#) field.

The screenshot shows the 'CCI Setup' window with a 'Settings' panel. The settings are as follows:

- UIM: Dual Port (dropdown menu)
- Port A - MAP27 Data Rate: 9600 (dropdown menu)
- Port B Auxiliary Data Rate: 9600 (dropdown menu)
- Bits Per Character: 8 (dropdown menu)
- Number Of Stop Bits: 1 (dropdown menu)
- Parity Type: None (dropdown menu)
- Handshaking Mode: None (dropdown menu)
- XON Character: 11 (text input)
- XOFF Character: 13 (text input)

UIM	UIM is the type of module fitted to the radio. Select Single Port (T2000-66 fitted), or Dual Port (T2000-60 fitted).
Port A - MAP27 Data Rate	Port A - MAP 27 Data Rate sets the baud rate on Port A. Select 1200 or 9600.
Port B Auxiliary Data Rate	Port B - Auxiliary Data Rate sets the baud rate on Port B. Select 600, 1200, 2400, 4800 or 9600.
Bits Per Character	The number of bits per character can be set for each port. The most common character set is 7 bit ASCII (CCITT alphabet No. 5). Select 7 or 8.
Number Of Stop Bits	The Number of Stop Bits sets the number of stop bits to append to each character for each port. Select from 1 or 2 stop bits.
Parity Type	Sets the parity for each port. Select from Even, Odd or None.
Handshaking Mode	Handshaking Mode enables the control of data flow for each port. Select from Hardware, Software or None.

XON Character	If <a href="#">Handshaking Mode</a> is Software, the XON character must be defined. When the radio detects this character, it will turn the flow of data on. Enter a hex number between 0 and FF.
XOFF Character	If the <a href="#">Handshaking Mode</a> is Software, the XOFF character must be defined. When the radio detects this character, it will turn the flow of data off. Enter a hex number between 0 and FF.

## Data Parameters Form

The Data Parameters form is used to define the parameters that govern data exchange via the Short Data Message facility and the Tait Data Protocol (TDP). For the Tait Data Protocol fields in this form to be enabled, the [MAP27 Interface](#) must be selected (Specifications Form).

The screenshot shows the 'Data Parameters' form with two main sections: 'Short Data Messages' and 'Tait Data Protocol'. In the 'Short Data Messages' section, 'Short Data Messages' and 'Call Queued Tones' are checked. The 'TGI Timer' is set to 5 and the 'TGG Timer' is set to 10. The 'SDM Despatcher Call String' field is empty. In the 'Tait Data Protocol' section, 'Tait Data Protocol' is checked. The 'Num Retries' is 5, 'Lead In Tone' is 200, 'Lead Out Tone' is 0, and 'SYND Sequence' is EB23. On the right side, 'Wait Ack' is 0.5, 'Timer DCI' is 500, 'A Wait' is 1, and 'B Wait' is 5.

### Short Data Messages

These settings govern whether the radio can send Short Data Messages (ASCII data) via a long press of the Status key and Alphanumeric key.

Short Data Messages	T2040 radios only. The Short Data Messages field enables <a href="#">T2040</a> radios to send <a href="#">Short Data Messages</a> using a long press of the Status key. <a href="#">Data Calls</a> (Call Options form) must be enabled for the radio to attempt to send a short data message.
TGI Timer	TGI Timer defines the length of time the radio is to wait for further signalling during short data calls for individual calls. If this timer lapses, any future short data signalling is assumed to be a new transaction. Enter a value from 0 to 16.
TGG Timer	TGG Timer defines the length of time the radio is to wait for further signalling during short data calls for group calls. If this timer lapses, any future short data signalling is assumed to be a new transaction. Enter a value from 1 to 30.

Call Queued Tones	When Call Queued Tones is enabled, the radio beeps periodically to indicate that there are calls in the queue.
SDM Despatcher Call String	Short Data Messages are sent to a radio identity (nn) by entering *nn# after the message. This field defines the call string that the message is sent to when # is pressed immediately after the message. Enter the radio identity of your data despatcher. Any trailing # symbols will be removed.
Hook Signalling	When Hook Signalling is enabled, the radio sends an off-hook signal to acknowledge the acceptance of the SDM or STATUS call setup request, and an on-hook signal once the call has been completed. This enables the radio to work correctly with certain mobile data terminal equipment (MDTs).

### Tait Data Protocol

Tait Data Protocol (TDP) is a non-prescribed data (NPD) format that requires the use of a [traffic channel](#).

Tait Data Protocol	When Tait Data Protocol is enabled, the radio may send or receive Non-Prescribed Data (NPD) calls using MAP27 over a traffic channel.
Num Retries	Num Retries sets the number of times the radio will attempt to resend a failed Tait Data Protocol codeword before clearing down the call. Enter a value from 1 to 16.
Lead In Tone	Lead In Tone sets the duration of the leader tone that is placed before all Tait Data Protocol codewords. This tone ensures that all repeaters are on and ready to receive the codeword. Select a time from the available options.
Lead Out Tone	Lead Out Tone sets the duration of the tone that follows all Tait data protocol codewords. This is used to ensure that squelch tail eliminators do not interfere with codewords. Select a time from the available options.
SYND Sequence	The SYND sequence defines the synchronisation data sequence to be used by Tait Data Protocol codewords. The definition must be different to both <a href="#">SYNC</a> and <a href="#">SYNT</a> to ensure that the system controller (TSC) doesn't try to decode the Tait Data Protocol codewords. Enter an appropriate hex number between 0 and FFFF.
Wait Ack	Wait Ack sets how long the radio is to wait for acknowledgement after sending a packet. Once this time has elapsed, the radio will resend the packet. Select a time from 5 to 15.
Timer DCI	Timer DCI sets how long the radio is to wait after each receive or transmit activity, before sending an empty packet to retain the link. Enter a value between 100 and 2000 in steps of 100.
A Wait	A Wait sets the length of time the radio is to wait before the first transmission after initiating a group call. This pause ensures that all parties have received the Go To Channel message. Enter a value between 1 and 15.
B Wait	B Wait sets the length of time the radio is to wait for contact during call setup before assuming that the channel has failed and clearing down the call. Enter a value between 5 and 15.

## Status Messages Form

Use the Status Messages form to set a list of status messages for the mobile.

Status	Display Message
1	STATUS01

Add Delete

**Status** The Status field sets the status value for the radio to transmit. Enter a value from 1 to 30.

**Display Message** The Display Message field assigns a meaningful label to the status value. [Status Calls](#) (Call Options form) must be enabled before Status messages may be sent. Enter a string between 1 and 8 characters in length in any combination of the characters A to Z, 0 to 9 or -.

Labels must be unique. Usable characters are in 10 groups. Characters in each group are regarded as identical, so that the label AGE is the same as the label BID.

The groups are as follows:

1
2,A,B,C
3,D,E,F
4,G,H,I
5,J,K,L
6,M,N,O
7,P,Q,R,S
8,T,U,V
9,W,X,Y,Z
0

## Power Saving (Trunked) Form

You can use the Power Saving form to set the mobile to minimise power consumption by switching off unnecessary circuitry when there is no traffic on the selected channel.

If the appropriate vehicle connections are present, the mobile will detect whether the vehicle's ignition is on or off, and respond appropriately. Any activity on the selected channel, or input from the user, will return the mobile to a fully active state.

The screenshot shows a 'Power Saving' configuration window with the following settings:

- Ignition On:**
  - Enable:
  - Time: 1
  - Unit: Hours
- Ignition Off:**
  - Enable:
  - Time: 1
  - Unit: Minutes
- Backlight:**
  - Economiser Backlighting Level: Off

**Ignition On Enable** If enabled, the radio will enter economy mode when the vehicle ignition is on and after the period indicated by the [Ignition On Time and Unit](#). This will occur if there has been no activity on the selected channel or input from the user.

If this field is unchecked, economy mode with the ignition on will be disabled.

**Ignition On Time and Unit** Enter a valid time and unit before the radio enters economy mode with the ignition on. This will occur if there has been no activity on the selected channel or input from the user. [Ignition On Enable](#) must be checked for these fields to be valid.

**Ignition Off Enable** If enabled, the radio will enter economy mode when the vehicle ignition is off and after the period indicated by the [Ignition Off Time and Unit](#). This will only occur if there has been no activity on the selected channel or input from the user.

If this field is unchecked, economy mode with the ignition on will be disabled.

**Ignition Off Time and Unit** Enter a valid time and unit before the radio enters economy mode with the ignition off. This will occur if there has been no activity on the selected channel or input from the user. [Ignition Off Enable](#) must be checked for these fields to be valid.

**Economiser Backlighting Level** Sets the backlighting level for the radio to use when the radio enters economy mode. Select Dim or Off.



## Preset Calls Form

The Preset Calls form is used to set a list of preset calls for the mobile. T2030 radios can have 4 preset calls, assigned to keys C1 to C4. T2035 radios can have up to 20 preset calls, accessed using the 1, 10 and 100 keys followed by the call key. T2040 radios can have up to 100 preset calls, accessed using the numeric keypad and the # key, or the scroll keys. T2040 radios also store these numbers (and optional label) as an alphanumeric entry.

ID	Label	Call String
0	FRED	212
1	ALLAN	213
2	PETER	214

**ID** The ID field sets the number of the preset call. MPT1343 recommends that preset 0 be used for calls to a PABX operator and that presets 1 to 9 be used for despatchers.

**Label** T2040 radios only.

The Label field sets an optional label for a preset call string. If a label is assigned to a preset call string then the user can activate the call string by entering or selecting the label using the alphanumeric key/cursor keys then #. The label will also be displayed if an incoming caller's identity matches the call string.

Enter a string of 1 to 8 characters in any combination of the characters A to Z, 0 to 9, or - . Labels must be unique. Usable characters are in 10 groups. Characters in each group are regarded as identical, so that the label AGE is the same as the label BID.

The groups are as follows:

1
2,A,B,C
3,D,E,F
4,G,H,I
5,J,K,L
6,M,N,O
7,P,Q,R,S
8,T,U,V
9,W,X,Y,Z
0

If no label is required, leave this field blank.

**Call String** Sets the string that the radio is to dial when the preset call is selected. Enter any valid dialling sequence. Allowable characters are 0 to 9, \* and #. Any trailing # symbols will be removed.

## 5 Digit Lookup Form

The Lookup Table for 5 Digit Interfleet Calls form is used to define 5-digit access strings that can be used to make [interfleet calls](#). This form applies only to fleets that use MPT numbering. If your network is not [MPT 1343](#) compliant, consult your network operator.

At least one of the [Interfleet Calls](#) or [Interfleet Group Calls](#) fields (in the Call Options form) must be enabled before any lookup entries can be made.

The screenshot shows a window titled "5 Digit Lookup" containing a table with the following data:

Prefix	Fleet	Fleet Type	Highest	Access String
▶ 200	2001	Individual	79	200NN

At the bottom right of the window are two buttons: "Add" and "Delete".

**Prefix** In MPT1343, the number prefix must be from 200 to 327. If you do not know the number prefix of the fleet to be called, or the network is not MPT1343 compliant, consult your network operator.

**Fleet Number** In MPT1343, the fleet number must be from 2001 to 6050. If you do not know the fleet number of the fleet to be called, or the network is not MPT1343 compliant, consult your network operator.

**Fleet Type** Fleet Type specifies whether the call is an Individual or a Group call. The types are the same for Interfleet calls as they are for normal in-fleet calls. Before individual Interfleet calls may be made [Interfleet Calls](#) (Call Options form) must be checked; before group Interfleet calls may be made [Interfleet Group Calls](#) (Call Options form) must be checked. Select Individual or Group.

**Highest** Highest defines the highest number in the fleet the user might wish to call. For the MPT1343 Dialling Scheme, if this lookup entry is being defined for individual calls then the number range is 20 to 89 or 200 to 899. If the lookup entry is being defined for group calls then the number range is 90 to 99, or 900 to 998. If you are unsure as to the correct highest number in the fleet for the fleet to be called, or your network is not MPT1343 compliant, consult your network operator.

Access String      The Access String displays the five digit, short form number that will dial the interfleet number.

## External Calls Form

The External Calls form is used to set the parameters for external calls initiated by internal logic input, such as a footswitch that activates an emergency (SOS) call. This form is available for T2040 radios only.

External Calls

External Call Request

ECR Call String #200

ECR Call Clear

Emergency Calls

SOS Calls

SOS Num Retries 20

SOS Call Time Limit 120

SOS Tx Time 8

SOS Rx Time 7

SOS Mute

ECR Call String      The ECR (External Call Request) Call String sets the number the mobile will dial when the external line to the radio's logic board is activated, for example, using a footswitch. Enter any valid dialling sequence using the characters 0-9, \*, #.

ECR Call Clear      If ECR Call Clear is checked, any current trunked call will end when the ECR (External Call Request) detection changes from active to inactive, for example when the user's foot is taken off the footswitch. This will mean that the recipient of the call cannot respond. If ECR Call Clear is disabled, then the call will remain active until it is ended manually using the Clear key.

This field is only valid if the [Silent SOS Calls](#) field is disabled.

Silent SOS Calls      Silent SOS Calls sets whether the mobile should process the ECR (External Call Request) Call String silently, with no audible or visual indicators. This is useful if the external call facility is to be used in emergency situations.

SOS Num Retries      SOS Num Retries sets the number of attempts the mobile will make to set up a call to the ECR Call String after failing to gain a traffic channel. Enter a number between 0 and 255.

SOS Call Time Limit      SOS Call Time Limit sets a total call time limit in seconds for SOS Calls. This time limit overrides any other time limits that might be in effect. Enter a value between 10 and 120.

SOS Tx Time	<p>The mobile automatically cycles between Receiving and Transmitting when it makes an SOS Call. SOS Tx Time sets how long the mobile should spend transmitting. Enter a value between 0 and 120 seconds.</p> <p>Ensure that the sum of SOS Tx Time and <a href="#">SOS Rx Time</a> do not exceed the <a href="#">SOS Call Time Limit</a>.</p>
SOS Rx Time	<p>The mobile automatically cycles between Receiving and Transmitting when it makes an SOS Call. SOS Rx Time sets how long the mobile should spend receiving. Enter a value between 0 and 120 seconds.</p> <p>Ensure that the sum of SOS Tx Time and <a href="#">SOS Rx Time</a> do not exceed the <a href="#">SOS Call Time Limit</a>.</p>
SOS Mute	<p>When this field is enabled and an SOS call (Emergency Mode Tx/Rx cycling) is made the Rx on the radio that initiated the call is muted. When disabled the Rx is unmuted. This allows the dispatcher to talk to the unit making the call.</p>

## Call Options Form



The fields in the Call Options form determine the types of calls a radio unit is permitted to make and how they are made. For information on the call strings that operate the various features on this form, see [“Trunking Call Strings” on page 126](#).

Abbreviated Dialling	<p>T2040 radios only.</p> <p>The trunking system can be configured so that radios on the system can make a call to the PSTN without dialling the full number. Enable the Abbreviated Dialling field to allow the radio to make use of this feature. <a href="#">Abbreviated dialling</a> will only work if the system node has been programmed with abbreviated number sequences. See your network operator for more information.</p> <p>If Abbreviated Dialling is enabled, you should also set the <a href="#">Abbreviated Dialling Limit</a>.</p>
Abbreviated Dialling Limit	<p>T2040 radios only.</p>

The Abbreviated Dialling Limit defines how many different [abbreviated dialling](#) numbers a unit can use. [Abbreviated Dialling](#) must be enabled for this field to be valid.

The radio permits entry of up to 49 abbreviated dialling calls but the network may not provide that many. Enter a value between 0 and 49. Consult your network operator to determine how many abbreviated dialling calls are available.

Don't Disturb	<p>T2040 radios only.</p> <p>Don't Disturb permits the user to set the radio to ignore incoming calls while still allowing outgoing calls to be made as usual. If disabled, the mobile always receives calls while it is switched on and in range of the network. These calls may be accepted or queued.</p>
PABX Calls	<p>T2040 radios only.</p> <p>The PABX Calls field permits the user to set up a <a href="#">PABX</a> (Private Automatic Branch Exchange) call.</p>
PSTN Calls	<p>T2040 radios only.</p> <p>The PSTN Calls field permits the user to set up a call to a <a href="#">PSTN</a> (Public Switched Telephone Network) subscriber.</p>
Interfleet Calls	<p>T2040 radios only.</p> <p>If enabled, permits the user to set up an <a href="#">interfleet call</a>. Mobiles on a network are grouped into 'fleets' of users. An 'Interfleet call' is a call between two users who are members of different fleets.</p> <p>This setting only makes individual Interfleet calls available. Group Interfleet calls can be made if <a href="#">Interfleet Group Calls</a> is enabled. Interfleet calls can be made using 5 digit access strings. See the "<a href="#">5 Digit Lookup Form</a>" on page 100 for more information.</p> <p>Unless there is a specific reason to allow this type of call, disable this field.</p>
Interfleet Group Calls	<p>T2040 radios only.</p> <p>When the Interfleet Group Calls field is enabled, the radio can make calls to groups of radios in other fleets (<a href="#">interfleet group call</a>). Individual <a href="#">interfleet calls</a> can be made if <a href="#">Interfleet Calls</a> is enabled. Interfleet group calls can be made using 5 digit access strings. See the "<a href="#">5 Digit Lookup Form</a>" on page 100 for more information.</p> <p>Unless there is a specific reason to allow this type of call, disable this field.</p>
ALLI Calls	<p>T2040 radios only.</p> <p>The ALLI Calls field permits the user to set up an <a href="#">ALLI call</a> (a call to all idents on a site). This facility is normally only used by network technicians.</p>
Network Operator Service Calls	<p>T2040 radios only.</p> <p>If Network Operator Service Calls is enabled, the user can set up a network operator service call. This service may be provided by the network operator to report faults, for example.</p>

Callback Facility	<p>If the Callback facility is enabled, when an answered incoming call is cleared down, its number is displayed. The radio user can then call back the calling radio by pressing the PTT.</p>
Radio Despatcher	<p>Use this field to set the radio to operate as a Despatcher. In this mode, the radio accepts the special 'Enter Despatch Queue' and 'Leave Despatcher Queue' calls and the radio never automatically switches between queue and normal display modes.</p> <p>These changes in operation are designed to be compatible with how a fixed location radio would be used compared to a mobile. Despatch radio operation is designed to use a call queue, so ensure that <a href="#">Call Queuing</a> is set to Full or Unanswered.</p>
Join Busy Group	<p>The Join Busy Group feature automatically directs the radio to the traffic channel of a busy group, when calling that group. If checked, and the radio calls a group that is already involved in a call, the radio is directed to the traffic channel that the group is using. Do not enable this field unless authorised to do so by your network operator.</p> <div style="display: flex; align-items: flex-start; margin-top: 10px;"> <div style="margin-right: 10px; text-align: center;">  </div> <div> <p><b>Note:</b> On systems that support group call amalgamation, the radio will automatically join busy groups regardless of the setting of this field.</p> </div> </div>
Technician Calls	<p>T2040 radios only.</p> <p>If enabled, the user can set up a special call to directly access any unit on the network. This facility is normally only used by network technicians.</p> <div style="display: flex; align-items: flex-start; margin-top: 10px;"> <div style="margin-right: 10px; text-align: center;">  </div> <div> <p><b>Note:</b> Do not enable this facility unless you are authorised to do so for this mobile by the network operator.</p> </div> </div>
Status Calls	<p>T2040 radios only.</p> <p>If enabled, the user can send a <a href="#">status</a> call. This is a coded message sent as a number from 1 to 30. It is used between two parties where the number has a prearranged meaning.</p> <p>If status calls are enabled, you should define status messages (<a href="#">Status Messages Form</a>) with the prearranged messages used in this fleet.</p>
Data Calls	<p>T2040 radios only.</p> <p>Sets whether the user may set up Data Calls such as Short Data Messages (SDMs) and other data over a traffic channel. The <a href="#">Short Data Messages</a> field (Data Parameters form) must be enabled to send SDMs. To send other data, the <a href="#">MAP27 Interface</a> (Specifications Form) must be enabled, and other fields on the <a href="#">CCI Setup (Trunked) Form</a> and <a href="#">Data Parameters Form</a> must be set correctly.</p>
Divert Own Calls	<p>T2040 radios only.</p> <p>If Divert Own Calls is enabled, the user can divert incoming calls to another unit or PSTN number.</p>
Divert Third Party Calls	<p>T2040 radios only.</p> <p>If Divert Third Party Calls is enabled, the user can divert another unit's incoming calls to another unit or PSTN number.</p>
Direct Despatcher Calls	<p>T2040 radios only.</p>

If Direct Dispatcher Calls is enabled, the user can make normal speech calls to the dispatcher. The dispatcher's number is defined in the [Prime Dispatcher Number](#) field (Fleet Parameters form).

If Direct Dispatcher Calls is disabled, users can still enter and leave the dispatcher's queue (if available) using the dial strings \*0# and #0#.

- Call Queuing      Call Queuing sets a queue to hold unanswered calls, automatically queued calls and status calls. Select Full, Unanswered or None.
- Full: Up to 20 calls will be queued.
  - Unanswered: Only unanswered calls and status calls will be queued.
  - None: Only a single unanswered call will be queued.

Desp Queue Req As Status      Desp Queue Req As Status allows queue add or delete requests to be treated as a status. With this field checked, the full range of status labels (0 to 31) will be available.

If Desp Queue Req As Status is unchecked, two status labels are reserved for adding and deleting from the queue.

## External Alert Form

Use the External Alert form to set the mobile to activate an external device, such as the car horn or lights, in response to an incoming call.

The screenshot shows a form titled "External Alert" with a "Parameters" section. The parameters are:

- Active Time: 0
- Delay Time: 15
- Sound: Pulsed
- Alert On Emergency Calls:
- Alert On Speech Calls:
- Alert On Data Calls:
- Alert On Include Calls:
- Alert On Status Calls:
- Alert On Group Calls:
- Alert On Individual Calls:

Active Time      Active Time sets how long the external alert remains on, once started. Enter a value between 1 and 60 seconds. Enter 0 to disable the External Alert.

Delay Time      Sets how long the mobile pauses after receiving an incoming call, before activating the external alert. Enter a value between 1 and 60 seconds. Enter 0 to activate the external alert immediately when receiving an incoming call.

Sound      Sets the signal pattern for the external alert. Select from Steady, Pulsed or Ringing.

Alert On Emergency Calls	<p>Enables or disables the external alert when receiving an emergency call (see “<a href="#">Trunking Call Strings</a>” on page 126). The alert will differ according to the settings in <a href="#">Active Time</a>, <a href="#">Delay Time</a> and <a href="#">Sound</a>.</p> <p>If you want to disable the external alert on all emergency calls, uncheck this field and disable <a href="#">Alert On Speech Calls</a> and <a href="#">Alert On Individual Calls</a>.</p>
Alert On Speech Calls	<p>Enables or disables the external alert when receiving a speech call (see “<a href="#">Trunking Call Strings</a>” on page 126). The alert will differ according to the settings in <a href="#">Active Time</a>, <a href="#">Delay Time</a> and <a href="#">Sound</a>.</p> <p>If you want to disable the external alert on all speech calls, uncheck this field and disable <a href="#">Alert On Individual Calls</a>.</p>
Alert On Data Calls	<p>Enables or disables the external alert receiving a status message, short data message or other data call (see “<a href="#">Trunking Call Strings</a>” on page 126). The alert will differ according to the settings in <a href="#">Active Time</a>, <a href="#">Delay Time</a> and <a href="#">Sound</a>.</p> <p>If you want to disable the external alert on all data calls, uncheck this field and disable <a href="#">Alert On Individual Calls</a>.</p>
Alert On Include Calls	<p>Enables or disables the external alert on Include Calls.</p>
Alert On Status Calls	<p>Use <a href="#">Alert On Data Calls</a> to enable or disable the external alert for Status Calls.</p>
Alert On Group Calls	<p>Enables or disables the external alert when receiving a group speech call (see “<a href="#">Trunking Call Strings</a>” on page 126). The alert will differ according to the settings in <a href="#">Active Time</a>, <a href="#">Delay Time</a> and <a href="#">Sound</a>.</p> <p>If you want to disable the external alert on all group speech calls, uncheck this field and disable <a href="#">Alert On Speech Calls</a>.</p>
Alert On Individual Calls	<p>Enable or disables the external alert when receiving all individual speech, data and emergency calls (see “<a href="#">Trunking Call Strings</a>” on page 126). The alert will differ according to the settings in <a href="#">Active Time</a>, <a href="#">Delay Time</a> and <a href="#">Sound</a>.</p> <p>If you want to disable the external alert for all individual calls, uncheck this field and disable <a href="#">Alert On Emergency Calls</a>, <a href="#">Alert On Speech Calls</a>, and <a href="#">Alert On Data Calls</a>.</p>



## Key Settings (Trunked) Form

The operation of various radio control head keys is set in the Key Settings form.

The screenshot shows the 'Key Settings' form with two main sections: 'Function Key' and 'Dispatcher Key'. The 'Function Key' section contains three fields: 'Mode' (a dropdown menu set to 'Preset Call'), 'Key Operation' (a dropdown menu set to 'Latching'), and 'Call String' (an empty text input field). The 'Dispatcher Key' section contains two fields: 'Call Queue On Long Press' (a checked checkbox) and 'Short Press Call String' (an empty text input field).

Mode	The Mode field sets an operation for the Function Button to perform. Select Auxiliary Output, External Alert, Preset Call or Disabled.
Key Operation	Key Operation controls the operation of the auxiliary output line when <b>Mode</b> is set to Auxiliary Output. Select Momentary to switch the Auxiliary Output line for only as long as the Function Button is pressed. Select Latching to toggle the Auxiliary Line permanently between settings each time the Function Button is pressed.
Call String	The Call String field defines a Preset Call String for the Function Button. Only available if <b>Mode</b> is set to Preset Call. Enter any valid dial string using the characters 0 - 9, * and #. See <a href="#">“Trunking Call Strings” on page 126</a> for more information on the different types of call strings available.
Call Queue On Long Press	If Call Queue On Long Press is enabled, a long press on the dispatcher button will change the mode of operation between call queuing and normal mode (equivalent to dialling *48#). If this field is disabled, a long press on the dispatcher button will be treated as a short press command, and the call string entered in <a href="#">Short Press Call String</a> will be dialed.
Short Press Call String	Short Press Call String assigns a call string to a short press of the Dispatcher button. Enter any valid dialling sequence. Allowable characters are 0 to 9, * and #.

## Interface Options Form

Initial settings for various radio features are set in the Interface Options form.

The screenshot shows the 'Interface Options' form with the following settings:

- Initial Settings:**
  - Normal Backlighting Level: Full (dropdown)
  - Auto Register at Power On:
- Call Initiation:**
  - PTT Initiation of Call:
  - Handsfree Call Initiation:
  - Single Press PTT Call:
- DTMF:**
  - DTMF Tones:
  - DTMF Timeout: 500 (text input)
- Diagnostics:**
  - Reset After Error:
  - Test Mode on Power Up:
- Audible Indicators:**
  - Keypress Confidence Tones:
  - Tone Set: Tait (dropdown)
  - Default Tone Level: Low (dropdown)
  - Suppress All Sound Tones:
  - Incoming Call Setup Tone:
  - Tone On Emergency Calls:
  - Tone On Speech Calls:
  - Tone On Data Calls:
  - Tone On Group Calls:
  - Tone On Individual Calls:
  - Tone On Include Calls:
  - Tone On Status Calls:

### Initial Settings

Fields in Initial Settings control how the radio will operate when it is first powered on.

Normal Backlighting Level

Normal Backlighting Level sets the backlighting level for the mobile when not in economy mode. Select from Full, Dim and Off.

Auto Register at Power On

When Auto Register at Power On is enabled, this option forces the radio to automatically re-register with the trunked network whenever the radio is powered up.

### Call Initiation

Fields in Call Initiation control how calls are made.

PTT Initiation of Call

If PTT Initiation of Call is enabled, a call is made to the number in the display when the user presses the PTT with the radio in an idle state and in trunked mode.

Handsfree Call Initiation

If Handsfree Call Initiation is enabled, a call is made to the number in the display when the footswitch is activated. For this to be valid the [Handsfree Interface](#) (Specifications form) must be selected, and voice activation must be disabled (refer to the T2000 Service Manual and relevant fitting instructions).

Single Press PTT Call

T2040 radios only.

If Single Press PTT Call is enabled and a call is initiated by the PTT, the radio user can begin talking while still pressing the PTT. When Single Press PTT Call is disabled and a call is initiated by the PTT, the PTT must be released then pressed again to begin talking. [PTT Initiation of Call](#) must be enabled for this to be valid.

## DTMF

Fields in DTMF control [DTMF](#) settings for T2040 radios with a DTMF module fitted.

DTMF Tones	T2040 radios only. Allows DTMF dialling on a traffic channel, if a DTMF module is fitted.
DTMF Timeout	T2040 radios only. DTMF Timeout sets the time between the release of the last key in a DTMF sequence, and the end of transmission. Enter a number between 100 and 2500 (ms).

## Diagnostics

Diagnostics sets the various radio states for diagnostics, such as what happens after a system error.

Reset After Error	If Reset After Error is enabled, the radio will reset five seconds after a system error.
Test Mode on Power Up	If Test Mode on Power Up is checked, the radio will power up in Test Mode after programming. The test mode facility enables the trunked radio to emulate a multichannel radio, utilising the frequencies reserved for trunking. The radio can then be tested and aligned. Refer to your T2000 Service Manual for more information on Test Mode. If unchecked, the radio will power-up in Trunked Mode after programming.

## Audible Indicators

Audible Indicators control the various tones that the mobile makes on certain events, such as powering up or down, or sending and receiving calls.

Keypress Confidence Tones	Keypress Confidence Tones enables or disables the audible confidence indicators that sound whenever a key is pressed. This setting does not affect warning or other tones.
Tone Set	Tone Set defines the style of audible indicators produced by the radio. Select Tait or MPT1343. <ul style="list-style-type: none"><li>■ Tait (for example, a ring each time a call is sent and received, or answered, and 4 short tones when a call is ended).</li><li>■ MPT1343 (for example, 2 short tones each time a call is sent and received, or answered and a high then low tone when a call is ended).</li></ul> The choice should be the same for all radios in the fleet.
Default Tone Level	Default Tone Level sets the sound level for audible indicators. Select Low or High.
Incoming Call Setup Tone	Incoming Call Setup Tone specifies whether the radio is to sound tones while incoming calls are being set up.
Suppress All Sound Tones	If Suppress All Sound Tones is enabled, any tone generated through the speaker will be silenced. This will not affect External Alert signals.

Tone On Emergency Calls	<p>Enables or disables the tone when successfully sending, receiving or ending an emergency call (see <a href="#">“Trunking Call Strings” on page 126</a>). The sound of the tone will differ according to the <a href="#">Tone Set</a>.</p> <p>If this field is enabled, <a href="#">Suppress All Sound Tones</a> must be disabled.</p> <p>If you want to disable the tone on all emergency calls, uncheck this field and disable <a href="#">Tone On Speech Calls</a> and <a href="#">Tone On Individual Calls</a>.</p>
Tone On Speech Calls	<p>Enables or disables the tone when successfully sending, receiving or ending a speech call (see <a href="#">“Trunking Call Strings” on page 126</a>). The sound of the tone will differ according to the <a href="#">Tone Set</a>.</p> <p>If this field is enabled, <a href="#">Suppress All Sound Tones</a> must be disabled.</p> <p>If you want to disable the tone on all speech calls, uncheck this field and disable <a href="#">Tone On Individual Calls</a>.</p>
Tone On Data Calls	<p>Enables or disables the tone when successfully sending, receiving or ending a status message, short data message or other data call (see <a href="#">“Trunking Call Strings” on page 126</a>). The sound of the tone will differ according to the <a href="#">Tone Set</a>.</p> <p>If this field is enabled, <a href="#">Suppress All Sound Tones</a> must be disabled.</p> <p>If you want to disable the tone on all data calls, uncheck this field and disable <a href="#">Tone On Individual Calls</a>.</p>
Tone On Group Calls	<p>Enables or disables the tone when successfully sending, receiving or ending a group speech call (see <a href="#">“Trunking Call Strings” on page 126</a>). The sound of the tone will differ according to the <a href="#">Tone Set</a>.</p> <p>If this field is enabled, <a href="#">Suppress All Sound Tones</a> must be disabled.</p> <p>If you want to disable the tone on all group speech calls, uncheck this field and disable <a href="#">Tone On Speech Calls</a>.</p>
Tone On Individual Calls	<p>Enable or disables the tone when successfully sending, receiving or ending individual speech, data and emergency calls.(see <a href="#">“Trunking Call Strings” on page 126</a>). The sound of the tone will differ according to the <a href="#">Tone Set</a>.</p> <p>If this field is enabled, <a href="#">Suppress All Sound Tones</a> must be disabled.</p> <p>If you want to disable the tone on all individual calls, uncheck this field and disable <a href="#">Tone On Emergency Calls</a>, <a href="#">Tone On Speech Calls</a>, and <a href="#">Tone On Data Calls</a>.</p>
Tone On Include Calls	<p>Enables or disables the tone on include calls.</p>
Tone On Status Calls	<p>Use <a href="#">Tone On Data Calls</a> to enable or disable the tone for Status Calls.</p>

# Part E Concepts

This part outlines basic concepts related to the T2000 Programming Application.

## Topics

- [Introduction to Channels and Scan Groups](#)
- [Introduction to Trunking](#)
- [Trunking Call Strings](#)



# Introduction to Channels and Scan Groups

---

This section contains basic concepts related to channels and scan groups.

## Squelch and Signalling: Filtering Out Unwanted Noise and Traffic

Without some mechanism for filtering what the radio broadcasts to the user, the radio's speaker would operate continuously and the user would hear not only any speech on a channel, but also all noise. This would be annoying for the radio user and so the radio filters out unwanted signals using various methods.

### Squelch

The squelch feature ensures that the speaker only unmutes when an intelligible signal is received. A signal is considered intelligible when it is strong enough to exceed a predetermined squelch threshold.



**Note:** Note that squelch is a preprogrammed feature present in all radios.

### Squelch Override

Squelch override is a programmable feature that allows the user to disable the radio's squelch and so hear all traffic on a channel, including noise.

In areas where signal strength is too weak to continually exceed the preprogrammed squelch threshold and so activate the speaker, a message may be periodically cut off by the squelch although it is still intelligible. Squelch override can then be activated by a long press of the monitor key, and the speaker is unmuted.

### Signalling Mutes

There are two signalling mutes available as programmable options which control the circumstances under which a received signal is passed to the radio's speaker. When a mute is active, the radio's speaker only unmutes under certain conditions, determined by the type of signalling operating on a channel.



**Note:** If your radio has been programmed for hookswitch monitor, removing the microphone from the microphone clip also overrides the signalling mutes.

There are two types of signalling mute.

- Subaudible signalling mute: The radio unmutes when a signal is received that has subaudible (CTCSS and DCS) signalling the radio recognises.
- Selective call mute: The radio unmutes when a signal is received that matches the radio's Selcall identity.

### Signalling

Squelch ensures that the radio user only hears intelligible signals, but the user hears all traffic on a channel. This could become a nuisance, particularly if several companies are using the same channel. Signalling provides a way of isolating groups of users so they only hear traffic intended for that group. It does not provide privacy since anyone tuning to a channel can hear its traffic if they wish, but it does minimise the possibility of radio users hearing nuisance traffic.

Signalling is non-voice coding on a channel for the purpose of identifying parties and/or segregating user groups. If a radio receives signalling that matches that programmed for the radio, the signalling is said to be valid and the radio's mute opens. Otherwise, the transmission is ignored and the radio remains silent, although the radio's channel busy indicator is activated.

The types of signalling available for T2010/T2015/T2020 radios are CTCSS, DCS and Selcall (Selcall multi-tone). Each channel can be programmed with different types of signalling, and subaudible signalling can be used on the same channel as Selcall signalling.

### **CTCSS and DCS**

CTCSS and DCS use subaudible signalling to segregate groups of users by transmitting additional information with normal speech.

For CTCSS the additional information is transmitted in the form of subaudible tones in the frequency band 67 to 250.3 Hz. For DCS the additional information is transmitted as digital data using frequencies between 10 and 134 Hz. The inverted DCS code may also be used, depending on the setting of the Rx DCS Polarity and Tx DCS Polarity fields in the Subaudible Signalling form.

Subaudible signalling is assigned on a per channel basis (in the [CTCSS/DCS Rx/Tx](#) fields, Channels form) and each channel can have different receive and transmit signalling.

T2020 radios also have 20 additional subaudible presets available, which are user selectable from the user function menu option. These presets override the signalling programmed for a channel in the Channels form and are set up in the [Subaudible Signalling Presets](#) tab.

The following tables show the CTCSS frequencies and DCS codes T2010/T2015/T2020 radios support.



### CTCSS Tone Frequencies

67.0	79.7	94.8	110.9	131.8	156.7	186.2	233.6
69.3	82.5	97.4	114.8	136.5	162.2	192.8	241.8
71.9	85.4	100.0	118.8	141.3	167.9	203.5	250.3
74.4	88.5	103.5	123.0	146.2	173.8	210.7	
77.0	91.5	107.2	127.3	151.4	179.9	225.7	

### Standard DCS Codes and Their Inverses

Code : Inv	Code : Inv	Code : Inv	Code : Inv	Code : Inv	Code : Inv
023 : 047	114 : 712	174 : 074	315 : 423	445 : 043	631 : 606
025 : 244	115 : 152	205 : 263	331 : 654	464 : 026	632 : 624
026 : 464	116 : 754	223 : 134	343 : 532	465 : 331	654 : 743
031 : 627	125 : 365	226 : 411	346 : 612	466 : 662	662 : 466
032 : 051	131 : 364	243 : 351	351 : 243	503 : 162	664 : 311
043 : 445	132 : 546	244 : 025	364 : 131	506 : 073	703 : 565
047 : 023	134 : 223	245 : 072	365 : 125	516 : 432	712 : 114
051 : 032	143 : 412	251 : 165	371 : 734	532 : 343	723 : 431
054 : 413	152 : 115	261 : 732	411 : 226	546 : 132	731 : 155
065 : 271	155 : 731	263 : 205	412 : 143	565 : 703	732 : 261
071 : 306	156 : 265	265 : 156	413 : 054	606 : 631	734 : 371
072 : 245	162 : 503	271 : 065	423 : 315	612 : 346	743 : 654
073 : 506	165 : 251	306 : 071	431 : 723	624 : 632	754 : 116
074 : 174	172 : 036	311 : 664	432 : 516	627 : 031	

### Non-Standard DCS Codes and Their Inverses

Code : Inv	Code : Inv	Code : Inv	Code : Inv	Code : Inv	Code : Inv
017 : 050	122 : 225	246 : 523	274 : 145	446 : 255	462 : 252
036 : 172	145 : 274	252 : 462	325 : 526	452 : 053	523 : 246
050 : 017	212 : 356	255 : 446	332 : 455	454 : 266	526 : 325
053 : 452	225 : 122	266 : 454	356 : 212	455 : 332	

### Selcall

Selcall uses sequences of audible tones to isolate calls in a manner similar to CTCSS and DCS. However, Selcall also allows individual radios to have a unique identity and so calls can be directed to specific individuals within a

group of radio users. Selcall is configured in a number of forms, depending on the radio model.

- Installed Selcall hardware is activated in the [Selcall Option](#) field (Specifications form).
- Selcall formats and sequences are set up in the [Selcall Identity](#) form. Three additional Selcall forms are available to T2020 radios (the [Selcall Features](#), [Selcall Status Definitions](#), and [Selcall Emergency](#) forms).
- Selcall sequences are associated with channels in the [Channels](#) form, [Tx Call](#) field.
- T2020 radios: Selcall emergency calling is configured in the [Selcall Emergency](#) form.

## Monitor: Listening In On Channel Traffic

Monitor allows the radio user to override a channel's signalling mutes and so hear all traffic on a channel.

When monitor is active, the mute is said to be open, or unmuted. When monitor is inactive, the radio is said to be in the quiet state, or muted.

The mutes (subaudible signalling mute, selective call mute) monitor disables is set in the [Monitor Function Disables](#) field (Receiver Monitoring form).

## Introduction to Scan Groups

A scan group is a group of 2 to 16 channels. Each channel that belongs to a scan group is called a member channel. Each member channel in a scan group is routinely sampled for valid activity (scanning) or greatest signal strength (voting).

There are three types of scanning and four types of voting available on T2010/T2015/T2020 radios.

### Scanning

In scanning, a group of channels is systematically sampled for activity. The member channels are scanned in the order in which they are assigned to the scan group ([Scan Group Members](#) tab).

The main benefit of scanning is that all channels of interest can be sampled for activity in a regular sequence. However, scanning takes a finite time (120 ms per channel, plus up to 350 ms for channels with subaudible signalling) to sample each member channel and so a short call could be missed within a large multi-member group.

Each scan group has a limited number of channels. Coverage of a large number of channels can be accomplished using several scan groups.

### *Types of Scanning*

There are three types of scanning available, and the type of scanning for a particular group is set in the [Scan Group Type](#) field (Scan Group Members tab). The three types of scanning are:

- Scanning (S)
- Priority Scanning (P)
- Dual Priority Scanning (DP)

### *Scanning (S)*

When scan group type is S (scanning), the radio scans all member channels to find a channel that is busy and has valid signalling. When valid activity is found, the radio remains on that channel until there is no longer valid activity and the group hold time has expired.

### *Priority Scanning (P)*

When scan group type is PS (priority scanning), the group's priority channel is scanned more frequently than other channels. If valid activity is found on another channel, the radio continues to scan the priority channel at regular intervals.

### *Dual Priority Scanning (DP)*

When scan group type is DPS (dual priority scanning), the radio behaves as for [Priority Scanning \(P\)](#), but there are two channels that are given higher priority. If valid activity is found on the first priority channel, no further scanning takes place. If valid activity is found on the second priority channel, the first channel continues to be scanned at regular intervals. If valid activity is found on a non-priority channel, the two priority channels are scanned periodically.

## **Scanning Regime**

The amount of time each channel is sampled depends on whether there is signalling on the channel, and on what type of signalling it is. When valid activity is found on a channel in the scan group, the channel is said to be captured and the radio stays on that channel until the activity ceases or is no longer valid. When activity is no longer valid, the radio stays on the last captured channel for the period of time specified by the [Group Hold Time](#) field (Scan Groups tab). Scanning then resumes.

If one or two priority channels have been assigned and the captured channel is not a priority channel (P1 or P2), the radio periodically leaves the captured channel to sample the priority channel(s) for activity. The user may notice the signal blanking out while the priority channel is sampled. If activity is found on a higher priority channel, the radio switches to that channel.

If for dual priority scanning the P2 channel is captured, the P1 channel continues to be scanned. If the P1 channel is captured, no further scanning takes place until the activity on the P1 channel is no longer valid.

## **Transmitting While Scanning**

While a scanning group is selected, all transmissions are made on the home channel, unless a channel is captured. While a channel is captured, all transmissions are made on that channel.

The home channel is the first channel defined as a [group member](#) in the Scan Group Members tab.

## **Voting**

In voting, a group of channels all carrying the same traffic (e.g. via linked repeaters) is systematically sampled (polled) for greatest signal strength. Voting provides wide area coverage and ensures that the strongest channel is always available for a call.

The member channels are polled in the order in which they are assigned to the scan group (Scan Group Members tab) until valid activity is found on one of the channels. After a delay specified in the [Voting Lead In Delay](#) field (Scan Groups tab), the received signal strength is measured for each channel. The strongest channel is then “voted” as the home channel on which all transmissions are made.

### **Initiating Polling**

Voting polling is initiated whenever:

- valid activity is detected on a channel or
- at a regular interval (the [Voting Polling Interval](#) (Scan Groups tab)).

### **Types of Voting**

There are four types of voting available, and the type of voting for a particular group is set in the [Scan Group Type](#) field (Scan Group Members tab). The four types of voting are:

- Voting (V)
- Voting With Signalling (VS)
- Double Voting (D)
- Double Voting With Signalling (DS)

#### *Voting (V)*

When Group Type is V (voting), the radio polls all member channels to find a busy channel. The radio then measures the signal strength of all channels and makes the channel with the strongest signal the home channel on which transmissions are made.

#### *Voting With Signalling (VS)*

When Group Type is VS (voting with signalling), the radio behaves as for Voting (V), but a channel must have valid signalling if it is to be made the home channel.

#### *Double Voting (D)*

When Group Type is D (double voting), the radio behaves as for Voting (V) but the signal strength of each channel is measured twice.

#### *Double Voting With Signalling (DS)*

When Group Type is DS (double voting with signalling), the radio behaves as for Voting With Signalling (VS), but the signal strength of each channel is measured twice.

### **Transmitting While Voting**

While a voting group is selected, all transmissions are made on the home channel. The home channel is the channel determined to have the strongest signal. If no channel has been selected as the strongest channel, the home channel is the first channel defined as a [group member](#) in the Scan Group Members tab.

# Introduction to Trunking

---

A trunking system is an efficient alternative to a conventional [repeater](#)-based system. In a conventional system, radio users compete for access to individual [channels](#), and one channel can be overloaded with traffic while others are virtually unused. A trunking system allows the automatic sharing of several channels by a number of radio users. Channels are pooled and allocated on demand for the duration of a call. As calls are completed, the channels are returned to the pool for allocation for other calls. Channel use is, therefore, optimised and the time each user must wait to make a call is reduced, as shown below.

## Key:

● Call in progress

○ Caller waiting

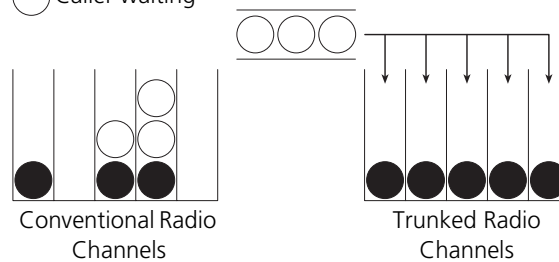

Thus each user has access to any free channel in a system. However, this access is under control of the trunking system and not under user control in much the same way as subscribers on the public switched telephone network make calls with equal priority but do not dictate the route that their call takes.

The function of the trunking system is complex; however, radio operation is simple because the system protocol and internal processing are transparent to the radio user. The use of microprocessors throughout the system adds features not found on conventional systems. Automatic call logging assists in monitoring the general performance on the system and provides data to bill trunking system subscribers according to their individual on air time.

## Control Channel Communication

One channel is designated the [control channel](#), which the [trunking system controller](#) (TSC) uses to communicate with all radios on the system. Radios listen to the control channel until they are directed to a traffic channel to participate in a call. Traffic channels are allocated by the channel control module for the duration of the call. At the end of a call, the radios revert back to monitor the control channel. The traffic channel is released into a standby mode awaiting the next allocation for a call.

The control channel communicates with the radios on the system using codewords. Every codeword is 64 bits long and consists of 48 bits of data and a 16-bit cyclical redundancy code (CRC), which is used for error checking. The codewords are sent over the control channel using fast frequency shift keying (FFSK), where a 1200 Hz tone represents digital one and an 1800 Hz tone represents digital zero.

A protocol called “slotted Aloha” is used to communicate over the control channel. All radios monitor the control channel’s frequency, communicating continuously with the TSC using the appropriate codewords. Every second the TSC broadcasts approximately 20 codewords to the radios, and every second there are approximately 10 opportunities for radios to send codewords to the TSC. In simple terms, the codewords sent from the TSC ask each radio in turn “do you want to make a call?” If the radio user has not initiated a call, the radio will respond “no”. If a call has been initiated, the radio will respond “yes”, together with the identity of the called party and the type of call.

The system can be set up so that different channels act as the control channel at different times. The system can also be set up so that if a priority call is attempted when there are no free channels, the control channel can temporarily act as a traffic channel.

A radio remains on the control channel until it requests and receives permission to make a call or until it is notified that a call is being set up. The call setup process for a radio-to-radio call in which the called radio is free and the calling radio ends the call is illustrated below.

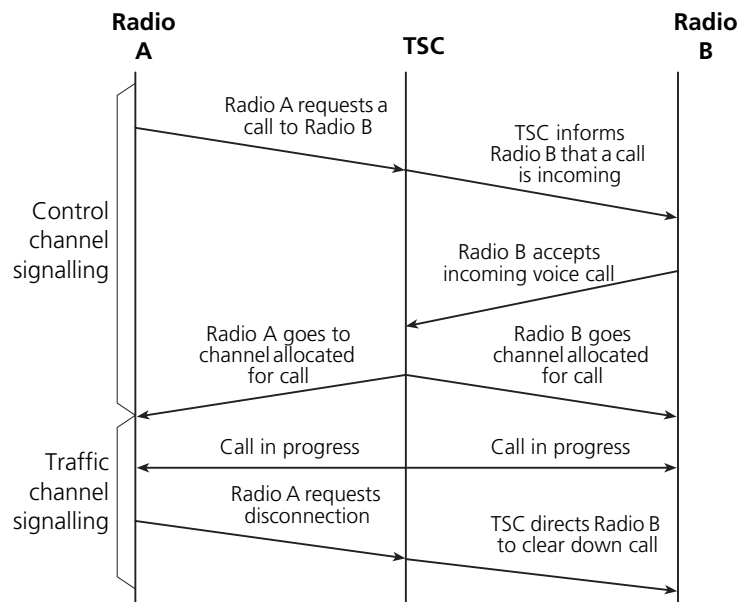

When the call is cleared down, both radios again monitor the control channel.

## Early Trunking Systems

Early trunking systems were usually based on five-tone [Selcall](#) or [DTMF](#) signalling but they had no common standard.

Over time, the radio spectrum became more crowded and so having some channels overloaded while others were virtually unused became less acceptable. In the early 1980s it became apparent that more efficient management of the frequency spectrum was necessary. The MPT 1327 and MPT 1343 standards were developed as part of the drive to make more efficient use of the frequency spectrum.

Both standards were published by the United Kingdom Department of Trade and Industry. MPT 1327 describes a signalling standard for trunked private land mobile radio systems. It describes the protocol used for communication between a [trunking system controller](#) (TSC) and the radios on the network. MPT 1343 describes the radio interface and outlines the minimum performance requirements for radios operating on MPT 1327-compliant networks. In short, MPT 1327 describes the communications protocol used between the network and the radios on the network, whereas MPT 1343 describes the radio performance and the interface between the radio and the radio user. The interactions on an MPT network are illustrated below.

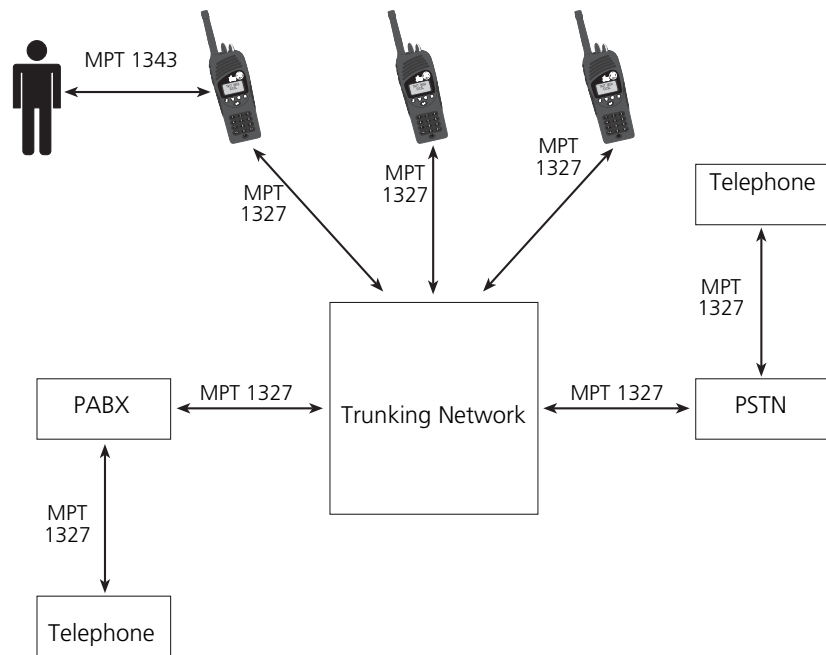

Since MPT 1327 and MPT 1343 were published, a number of variants of the MPT 1343 specification have arisen that offer different radio-user interfaces, which are commonly referred to as dialling schemes. Tait trunked radios are designed to operate on MPT 1327-compliant networks and support the following MPT 1327-compatible dialling schemes:

- MPT 1343
- CPSX
- Nokia ANN
- ZVEI
- Number Presets

## Addressing

A unique identity number is programmed into each radio operating on a trunking network so the radio can be contacted by the TSC and, thus, by the other users of the system. The identity number consists of a unique number for the radio and numerical information shared with the other members of the same organisation, or fleet. The identity of each radio provides a unique address that allows it to be contacted by members of the same fleet and other fleets using the same trunking network.

MPT 1327 and MPT 1343 specify different but related numbering schemes for addressing trunked radios.

- MPT 1327 specifies the numbering scheme used for identifying radios on a network. MPT 1327 numbers are used for all communications between all elements of the trunking network, including the radios operating on that network.
- MPT 1343 specifies the numbering scheme used by radio users. The MPT 1343 numbering scheme is simpler than the MPT 1327 format and allows radio users to address radios without having to remember long addresses. Typically it is possible to make a call by dialling only a two- or three-digit number.

As discussed in “[Early Trunking Systems](#)” on page 120, variants of the MPT 1343 specification have arisen that offer different radio-radio user interfaces, which are commonly referred to as dialling schemes. These dialling schemes include:

- [CPSX dialling](#)
- [Nokia ANN](#)
- [ZVEI](#)

## MPT 1327 Numbering

MPT 1327 numbers are used by the [trunking system controller](#) for communicating with radios and other devices on the network.

Under MPT 1327, each radio is assigned a unique identity as follows:

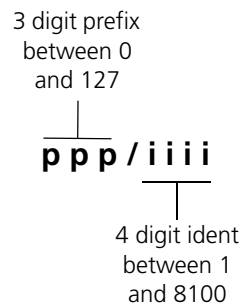

The 3-digit prefix merely extends the range of numbers available for addressing.

The available idents (1 to 8100) are divided to provide individual and group addresses. A block of idents are usually allocated for use by a particular fleet. Idents 0 and above 8100 are reserved for addressing special destinations, such as [PABX](#) and [PSTN](#) numbers.

## MPT 1343 Numbering

Under MPT 1343, radios on a network are divided into fleets. Since a trunking system is used by many different organisations, a fleet usually includes all the radios of a single organisation, although a large organisation could have several fleets on the network.

All radios within a fleet have the same fleet number and it is usually possible to make calls between radios in different fleets. Each radio in a fleet has a two- or three-digit unit number that is assigned to only one radio in the fleet. If the radio number is two digits, there can be up to 70 radios in that fleet; if the radio number is three digits, there can be up to 700 radios in the fleet. The diagram below illustrates MPT 1343 radio numbering.



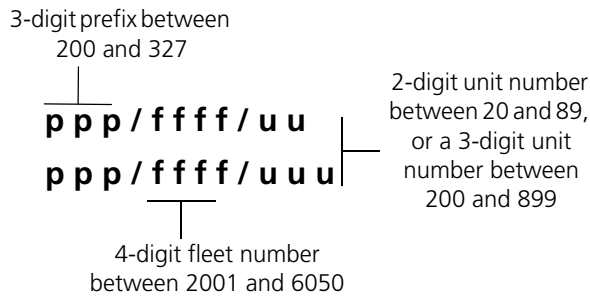

MPT 1343 allows radios to be grouped together so that calls can be received simultaneously. A range of numbers (called group numbers) are reserved for identifying groups of radios, and one or more radio units may be associated with that group number (subscribed to the group). These two- or three-digit group numbers are used in place of the radio unit number, as illustrated below.

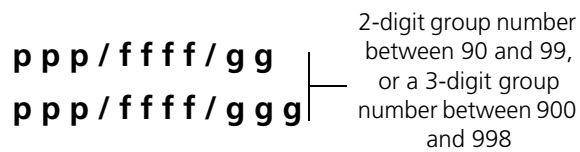

To make a call to another radio, the radio user dials an MPT 1343 number, which is converted to MPT 1327 for communication with the TSC and the receiving radio. In the receiving radio, the MPT 1327 number is converted to MPT 1343 for displaying to the radio user.

In order for the addresses to be converted correctly:

- the trunking system must be aware of how the available idents are partitioned into fleets, and
- the radios must be aware of the base ident of their own fleet.

### CPSX Dialling

As with MPT 1343 numbering, radios using CPSX dialling have a prefix, fleet number and unit number, as illustrated below.

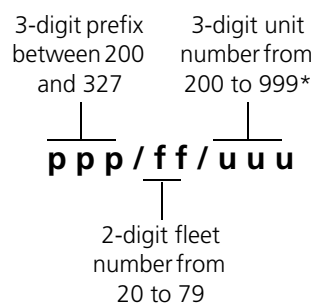

\*Unit numbers 900 to 999 are reserved for groups.

The prefix allocation is identical to MPT 1343, but:

- the fleet number is two digits, from 20 to 79
- the unit number is three digits, from 200 to 999
- unit numbers from 900 to 999 are reserved for groups

- individual and group numbers use the same fleet number.

Within each prefix, there are 8100 user addresses, which are divided into ten blocks of 810 addresses each. Three parameters, Large, Medium and Small, specify how the number and size of fleets within those blocks of 810 addresses. There are four options for fleet size:

- Large: 700 units
- Medium: 354 units
- Small: 236 units
- Tiny: 118 units.

The number of blocks allocated as large, medium, small and tiny fleets in a prefix is calculated as follows.

$$\begin{aligned} \text{Large fleets} &= l \\ \text{Medium fleets} &= 2(m - l) \\ \text{Small fleets} &= 3(s - m) \\ \text{Tiny fleets} &= 6(10 - s) \end{aligned}$$

So if parameters *Large*, *Medium* and *Small* are 2, 7 and 9 respectively, there are:

- 2 blocks of large fleets = 2 large fleets
- 5 blocks of medium fleets = 10 medium fleets
- 2 blocks of small fleets = 6 small fleets
- 1 block of tiny fleets = 6 tiny fleets

The allocation of fleets throughout the prefix's 8100 idents, for this example, is as illustrated in the diagram below.

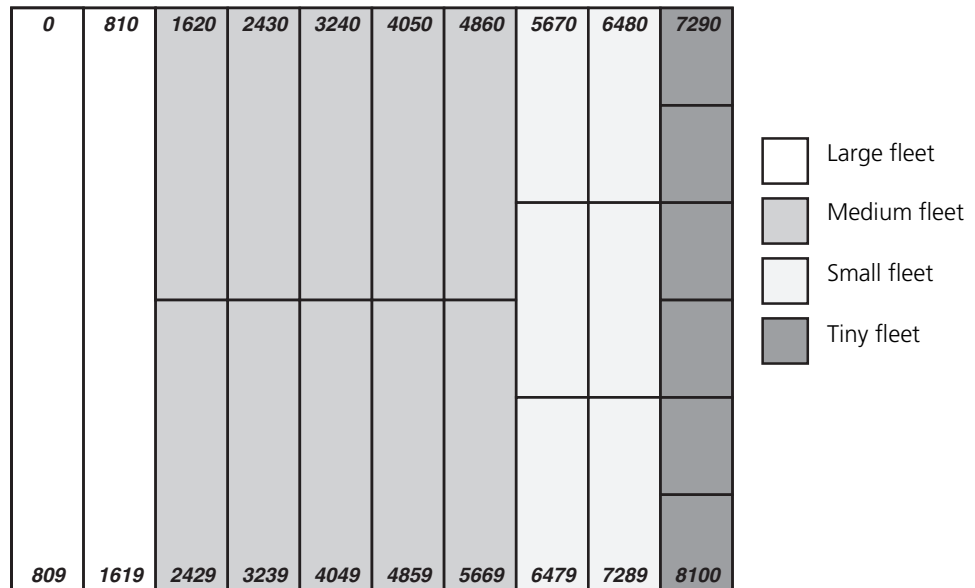

Note that within each prefix, fleets are grouped together according to size. That is, all large fleets will be allocated to the lower idents and all tiny fleets will be allocated to the higher idents.

Within each fleet, there is a range of individual and group addresses. For each fleet size, the possibilities are:

<b>Fleet Size</b>	<b>Radios</b>	<b>Groups</b>	<b>Radio Number Range</b>	<b>Group Number Range</b>
Large	700	100	200 to 899	900 to 999
Medium	354	51	200 to 553	900 to 950
Small	236	34	200 to 435	900 to 933
Tiny	118	17	200 to 317	900 to 916

Under CPSX dialling, the number of digits the radio user is required to dial is only five for interfleet calls (as opposed to 6 or 7 under MPT 1343) and eight for interprefix calls (as opposed to 9 or 10 under MPT 1343). Radios can display the caller's identity for interfleet and interprefix calls, whereas under MPT 1343 radios can only indicate that the call is from outside the fleet or prefix.

# Trunking Call Strings

Note that you cannot enter these strings directly into T2030 and T2035 radios. They will have to be set up as preset calls (using the [Preset Calls Form](#)).

Table 5: MPT1343 Common Call Setup

Dialling String	Call To	Example
<b>0</b>	PSTN number	<b>0 03 3456789 #</b>
<b>20 to 89</b>	Radio in same fleet as you (nn)	<b>89 #</b>
<b>200 to 899</b>	Radio in same fleet as you (nnn)	<b>899 #</b>
<b>2001 to 6050</b>	Radio in another fleet with same prefix as you	<b>6050 nn #</b>
<b>200 to 327</b>	Radio in another fleet with different prefix to you	<b>327 6050 nn #</b>
<b>90 to 99</b>	Group in same fleet as you (GG)	<b>90 #</b>
<b>900 to 999</b>	Group in same fleet as you (GGG)	<b>900 #</b>

Table 6: ANN Fleet Calls

Fleet Size	Call To	Example
<b>Large</b>	Radio 234 in Fleet 1 with same prefix as you	<b>7 1 234 #</b>
	Radio 235 in Fleet 2 with different prefix i.e. 32	<b>7 32 2 235 #</b>
<b>Medium</b>	Radio 23 in Fleet 51 with same prefix as you	<b>7 51 23 #</b>
	Radio 23 in Fleet 52 with different prefix i.e. 126	<b>7 126 52 23 #</b>
<b>Small</b>	Radio 23 in Fleet 80 with same prefix as you	<b>7 (8or9) 80 23 #</b>
	Radio 23 in Fleet 81 with different prefix to you i.e. 3	<b>9 3 81 23 #</b>

Table 7: CPSX Dialling Calls

Call Type	Call To	Example
<b>Own fleet</b>	Radio 213 in Fleet 34 in same fleet as you	<b>213 #</b>
<b>Interfleet</b>	Radio 215 in Fleet 36 (another fleet)	<b>36 215 #</b>
<b>Interprefix</b>	Radio 217 in Fleet 38 (another fleet) of Prefix 202	<b>202 38 217 #</b>

Table 8: Preset Calls

Dialling String	To	Example
<b>0 then 0 to 99 #</b>	Preset strings (leading zero)	<b>069 #</b>

Table 9: Conventional Channels

Dialling String	To	Example
<b>101 to 110 #</b>	Conventional channels	<b>106 #</b>

Table 10: Special Functions using “\*...#”

Dialling Code	Function	Example
<b>*0#</b>	Request Base Despatcher Callback	<b>*0#</b>
<b>*0*nnn#</b>	Request another Despatcher Callback	<b>*0*234#</b>
<b>*0ss*nn#</b>	Status Call (ss = Status 01 to 30)	<b>*015*23#</b>
<b>*0ss#</b>	Status Call to Despatcher (ss = Status 01 to 30)	<b>*015#</b>
<b>*1*nn#</b>	Conference Call to Group nn	<b>*1*92#</b>
<b>*11*nn#</b>	Broadcast Call to Group nn	<b>*11*923#</b>
<b>*31*nn#</b>	Non-prescribed Data Calls	<b>*31*23#</b>
<b>*41*nn#</b>	Divert Own Calls to Radio nn	<b>*41*23#</b>
<b>*41*0nn...#</b> <b>*44*nn*mm#</b>	Divert Own Calls to PSTN nn Divert 3rd Party Calls nn to mm	<b>*41*00335...#</b> <b>*44*23*21#</b>
<b>*48#</b>	Queue Incoming Calls	<b>*48#</b>
<b>*49#</b>	Do Not Disturb	<b>*49#</b>
<b>*700#</b>	Display name of the current network	<b>*700#</b>
<b>*70n#</b>	Change to network n (1 or 2)	<b>*701#</b>
<b>*8*nn#</b>	Priority Call to Radio nn	<b>*8*23#</b>
<b>*8*1*9n#</b>	Priority Conference Call to Group nn	<b>*9*1*923#</b>
<b>*9*nn#</b>	Emergency Call to Radio nn	<b>*9*23#</b>
<b>*9*1*9n#</b>	Emergency Conference Call to Group nn	<b>*9*1*92#</b>
<b>**nn#</b>	Abbreviated Dialed Codes (1 * 49)	<b>**3#</b>

Table 11: Special Functions Using “#...#”

Dialling Code	Function	Example
<b>#0#</b>	Cancel Base Despatcher Callback	<b>#0#</b>
<b>#0*nnn#</b>	Cancel another Despatcher Callback	<b>#0*234#</b>
<b>#41#</b>	Cancel Own Call Diversion	<b>#41#</b>
<b>#44*nn#</b>	Cancel 3rd Party Call Diversion	<b>#44*23#</b>
<b>#45#</b>	Cancel Incoming Call Diversions	<b>#45#</b>
<b>#48#</b>	Cancel Queuing of Incoming Calls	<b>#48#</b>
<b>#49#</b>	Cancel Do Not Disturb	<b>#49#</b>



# Part F Troubleshooting

This part outlines common problems related to the T2000 Programming Application.

## Topics

- [No appropriate licence to use this functionality](#)
- [Cannot see the forms tree](#)
- [Cannot find a field](#)
- [Cannot enable a field](#)
- [Radio won't read or program](#)
- [Checksum Error](#)





## No appropriate licence to use this functionality

The application displays the following message when starting:

“You do not have an appropriate license to use this functionality”.

One or more system files have not been registered during installation due to the computer not restarting when prompted. Restart your PC.

## Cannot see the forms tree

The windows have been resized so the forms tree is no longer visible. Click and drag the bar to the right of the tree view to display it.

## Cannot find a field

- Field is factory only and can only be viewed with a dongle.
- Field is on another form. Search the online help for more information on the field and where to find it.

## Cannot enable a field

- Field is disabled for that access level. Select a higher Access Level (Tools > Access Levels).
- Another field is be disabling it. Use What's This help (click the toolbar icon or press Shift+F1) for help on how to enable the field.

## Radio won't read or program

- The wrong Communication Port has been selected. Select another Communication Port in Tools > Options.
- The programming cable between the Communication Port and the Radio is not connected properly. Make sure all cables are working and are connected.

## Checksum Error

The application displays a message: “Checksum failed for item ...” when attempting to load a file.

This means that some of the data in the file is corrupt. The application will attempt to load what data it can.

After the file is loaded, check each field carefully for values that have been set back to the default, and change where necessary.

## Subaudible Signalling Does Not Work

Check that the [Monitor Function Disables](#) field (Receiver Monitoring form) is set to Selcall Mute. If set to All Mutes then the radio will hear all activity on the channel, even with different [Rx and Tx Signalling](#) values (Channels form).

## Scanning Does Not Work

Check that Off Hook Scanning is enabled (Channels form for T2010/T2015 radios, Scan Groups form for T2020 radios).

If Selcall is being used with scanning, the [Lead In Delay](#) (Selcall Setup tab) should be set to a value equivalent to the time it takes for a scan group to do one complete scan of all channels (for example, higher than 500 ms).

# Glossary

---

This part contains a list of key words and phrases used in the programming application.

## A

- abbreviated dialling** The trunking system can be configured so that radios on the system can make a call to a [PABX/PSTN](#) number without dialling the full number. Abbreviated dialling will only work if the system node has been programmed with abbreviated number sequences.
- access level** The access level determines the fields and forms that are editable. The access level depends on the option selected under Tools > Access Level.
- ACK** ACK is short for acknowledgement. An acknowledgment is a signal sent by a called radio unit as part of the call setup procedure.
- acquisition** Trunked radios only.  
When a radio has successfully acquired a [control channel](#), it is permitted to transmit and receive on that channel. The radio will listen to the control channel until it is directed to a [traffic channel](#) to participate in a call.
- address** Trunked radios only.  
The address is the [20-bit](#) number by which a radio unit or [group](#) of units is known on a [network](#)
- address codeword** Trunked radios only.  
An address codeword is a [64-bit codeword](#) that conforms to the requirements of [MPT 1327](#) and in which the first bit is set to 1. An address codeword is always the first codeword in any message and defines the nature of the message.
- ALLI call** Trunked radios only.  
An ALLI (all idents) call is a call to all radio units on a [trunking system](#).
- alpha symbol** Alpha symbols are a T2020 feature.  
An alpha symbol is a sequence of commands that can change to a specific channel, dial a Selcall or DTMF call, change the radio's status, or any combination of these three tasks. Up to 20 alpha symbols can be defined and these are available through [alphanumeric entry mode](#).  
Alpha symbols are defined in the Alpha Symbols form.
- alphanumeric entry mode** In alphanumeric entry mode on T2020 radios, the user can select and execute up to 20 [alpha symbols](#). Alphanumeric entry mode is available once an alpha symbol has been defined in the Alpha Symbols form.

For T2040 radios, alphanumeric mode allows the user to execute a call using a predefined label set in the Preset Calls form, and also send [short data messages](#).

## **ANI**

ANI is a [Selcall](#) feature.

ANI (automatic number identification) is a tone sequence transmitted during voice transmission in order to identify the radio in use.

Selcall calls can be set up so that each radio automatically transmits its ANI identity on each exchange of transmissions (each press of the PTT), unless the [ANI suppression time](#) has not expired. ANI makes it possible to set up a log of a radio's channel activity.

T2020 radios can also decode a Selcall ANI call and display the identity of the caller. To do this, the call must match the [receive \(Rx\) format](#), and there can be no C (caller identity) burst in the Rx format.

The key difference between ANI and [automatic caller identification](#) is that with automatic caller identification, only the radio receiving the call displays the identity of the radio transmitting on the channel. For ANI, any radio that has ANI decoding enabled can see which radios are using a channel.

Selcall ANI encoding is setup in the Selcall Setup and Selcall Identity tabs and Selcall ANI decoding is enabled in the Selcall Features form.

## **ANI suppression time**

The ANI suppression time is the minimum amount of time between subsequent transmissions of an [ANI](#) sequence.

The ANI suppression time is set in the Selcall Setup tab (Selcall ANI).

## **audible indicators**

T2000 radios use combinations of audible indicators and visual displays to indicate the radio's current state and activity.

Audible indicators include [keypress confidence tones](#), received call signals, low battery and high temperature warnings, [transmit timer](#) and unanswered call signals.

Audible indicators are enabled in the User Selectable form (conventional radios) and Interface Options form (trunked radios)

## **auto acknowledge**

Auto acknowledge is a Selcall feature.

When a radio receives a Selcall sequence that contains its identity, it can be programmed to transmit an auto acknowledge sequence.

An auto acknowledge sequence can also include a [status digit](#). On T2020 radios, if the [called unit status display](#) feature is enabled, a [status](#) is displayed upon receipt of the auto acknowledge.

Auto acknowledge is setup in the Selcall Setup and Selcall Identity tabs.

## **auto quiet timer**

The auto quiet timer determines how long [monitor](#) remains active. The auto quiet timer is suspended while the radio is transmitting or while there is [valid activity](#) on a channel. Once a transmission is complete or when the radio is switched to another channel, the auto quiet timer resets to the programmed duration of the auto quiet timer.

The duration of the auto quiet timer is set in the Receiver Monitoring form.

<b>automatic caller identification</b>	<p>Automatic caller identification is a T2020 Selcall feature.</p> <p>When an incoming call is received that matches the radio's <a href="#">Rx decode sequence</a>, the caller identity is displayed so the radio user can identify the caller before responding.</p> <p>Automatic caller identification only works if there is a C (caller identity) <a href="#">burst</a> in the <a href="#">receive (Rx) format</a>, and is enabled in the Selcall Features form.</p>
<b>B</b>	
<b>background hunt</b>	<p>Trunked radios only.</p> <p>A background hunt is carried out as part of the <a href="#">control channel acquisition</a> procedure. The background hunt is a method prescribed in <a href="#">MPT 1343</a> for monitoring other control channels and migrating to a superior channel when one is found. The background search is performed by periodically leaving the current control channel and sampling other control channels. What channels are sampled is specified in the <a href="#">Normal Hunt Channels Grid (Hunting Parameters)</a> form). If a channel is consistently found for a certain number of consecutive samples to be preferred (according to the NDD preference data defined in the <a href="#">Acquisition Data</a> form) or stronger than the current control channel by a certain margin, the radio will perform a <a href="#">preferential hunt</a> to acquire the new control channel.</p>
<b>backlighting</b>	<p>On T2020 and T2040 radios the control head <a href="#">LCD</a> lights up when there is activity on the radio, such as when a key is pressed or when a call is received. The LCD backlighting can be set to either bright or dim and, on T2020 and T2040 radios, can also be dimmed when the radio is in <a href="#">economy mode</a>.</p> <p>Backlighting settings are made in the User Selectable form (conventional radios) and the Interface Options form (trunked radios).</p>
<b>birdie</b>	<p>A birdie is a hum or whistle on a channel caused by internal interference. A birdie can be eliminated by activating a <a href="#">birdie killer</a> on the channel.</p>
<b>birdie killer</b>	<p>A birdie killer is an internal circuitry switch that greatly reduces the effect of a <a href="#">birdie</a> on a channel.</p> <p>Channels needing birdie killers are assigned in the Birdie Channels form (conventional radios only).</p>
<b>bit</b>	<p>Bit is an abbreviation for a binary digit consisting of either a 0 or a 1. Eight bits are equivalent to one <a href="#">byte</a>.</p>
<b>broadcast call</b>	<p>Trunked radios only.</p> <p>A broadcast call is a <a href="#">group call</a> in which only the radio user who initiated the call may speak. Contrast with <a href="#">conference call</a>.</p> <p>In a broadcast call, all radios in the group are directed to the same <a href="#">traffic channel</a> for the duration of the call. However, the call is cleared down as soon as the announcement is delivered and the recipients are not given an opportunity to respond.</p>

**buffered dialling** When a [DTMF string](#) is dialled, the string is either transmitted separately as each individual key is pressed ([normal dialling](#)) or in its entirety once the enter key is pressed (buffered dialling).  
The DTMF dialling type is set in the DTMF form (conventional radios only).

**burst** A burst is a series of [tones](#) (a [tone burst](#)) or [gaps](#) (a [gap burst](#)) in a [Selcall sequence](#).

**byte** A byte is a group of 8 [bits](#). Half of a byte is a nibble. Computer memory is measured in kilobytes or megabytes.

## C

**call diversion** For T2020 radios, call diversion allows the radio user to divert received calls to another channel. The radio recognises a call diversion message from another radio, and switches to the designated channel. T2020 radios can only divert calls to a portable radio (such as a Tait Orca), not to another T2000 mobile radio. For call diversion to operate correctly, an auto acknowledge is required (Selcall Identity tab). Call diversion is enabled in the Selcall Features form.  
For trunked radios, call diversion allows the radio user to divert received calls to another address, such as another radio or a [PSTN](#) or [PABX](#) number. Call diversion is enabled in the [Call Options Form](#).

**call queuing** If the radio user is unable to answer calls immediately, they can be stored in the call queue so that the user can call back later. Up to 10 calls can be stored for T2020 radios and up to 20 calls can be queued for trunked radios.  
Call queuing is enabled in the Selcall Features form for T2020 radios and the Call Options form for trunked radios.

**callback** Trunked radios only.  
When an incoming call is terminated, a radio may be programmed to display the caller's identity. If the radio user wishes to call the party back, they can do so by pressing the enter key.

**called unit status display** Called unit status display is a T2020 Selcall feature.  
When a called radio responds with an [auto acknowledge](#) that contains a [status digit](#), the auto acknowledge sequence is displayed on the calling radio, together with any attached status message.  
Called unit status display is enabled in the Selcall Features form.

**caller identity** In a [Selcall sequence](#), the caller identity is the part of the sequence that identifies the radio transmitting the sequence. In the [transmit \(Tx\) format](#) and [receive \(Rx\) format](#), the caller identity is represented by the character C, and so this part of a sequence is known as the C burst.

**captured channel** When the radio is scanning a group of channels and valid activity is found on one of those channels, the radio remains on that channel until the activity is no longer valid and the group hold time (scan hold time on T2010 radios) has expired or until valid activity is found on a higher priority channel. While the radio is stopped on that channel, the channel is said to be captured, and transmissions are on the captured channel rather than on the home channel.

**captured priority sample timer** The value of the captured priority sample timer determines how often priority channels are scanned when a lower priority channel is captured. The duration of the captured priority sample timer is set in the Scan Groups tab.

**CCI** See computer controlled interface.

**CCIR** CCIR is one of the Selcall tone sets the T2000 Programming Application supports. Note that E is the repeat tone.

Tone : Frequency (Hz)	Tone : Frequency (Hz)
0 : 1981	8 : 1747
1 : 1124	9 : 1860
2 : 1197	A : 2400
3 : 1275	B : 930
4 : 1358	C : 2247
5 : 1446	D : 991
6 : 1540	E : 2110
7 : 1640	F : 1055

**CCSC** Trunked radios only.

CCSC stands for Control Channel System Codeword. The CCSC is used in MPT 1327 and MPT 1343 to identify the system to radio units and provides synchronisation for the address codeword that follows.

**channel** A channel is a pair of radio frequencies, one used for transmitting and one used for receiving.

For conventional radios, channels are set up in the Channels form. For trunked radios, channels used by the trunking system are set up in the Trunked Channel Blocks form. The channels used in conventional channel operation are set up in the Conventional Channels form.

**channel entry/selection mode** In channel entry mode, or channel selection mode, the user can change to a different channel or scan group. Channel entry mode is automatically available on all conventional radios.

<b>channel spacing</b>	<p>Channel spacing is the interval between <a href="#">channels</a>. For T2000 radios, this is 12.5, 20 or 25 kHz. Wideband radios can be programmed for 20 and 25 kHz channel spacing only. Narrowband radios can be programmed for 12.5, 20 and 25 kHz channel spacing.</p> <p>Channel spacing depends on IF bandwidth (wide or narrow), which is hardware dependant and is defined in the Channels form (conventional radios).</p> <p>For trunked radios, channel spacing for the <a href="#">trunking system channels</a> is set in the <a href="#">Trunked Channel Blocks</a> form. Channel spacing for <a href="#">conventional channel operation</a> is set in the <a href="#">Conventional Channels</a> form.</p>
<b>codeword</b>	<p>Messages on a <a href="#">trunking system</a> are transmitted as codewords. Every codeword is 64 bits long and consists of 48 bits of data and a 16-bit cyclical redundancy code (CRC), which is used for error checking. The codewords are sent over the control channel using fast frequency shift keying (FFSK), where a 1200 Hz tone represents digital one and an 1800 Hz tone represents digital zero.</p> <p>The two types of codeword are: <a href="#">address codeword</a> and <a href="#">data codeword</a>.</p>
<b>comprehensive hunt</b>	<p>Trunked radios only.</p> <p>A comprehensive hunt is carried out as part of the <a href="#">control channel acquisition</a> procedure. When the control channel acquisition procedure has failed to identify a suitable <a href="#">control channel</a>, the radio will then search through all channels in the <a href="#">trunked channel blocks</a> defined for the radio, except those specified as non-applicable in the <a href="#">Non Applicable Channels Grid</a>.</p>
<b>computer controlled interface</b>	<p>The computer controlled interface (CCI) provides a means of controlling T2020/T2030/T2035/T2040 radios from some form of computer equipment. The CCI allows for the implementation of semi- and fully-automatic communications systems such as short data messaging (SDM), computerised despatch terminals, remote outstations and data radio terminals.</p> <p>Settings for the computer controlled interface are made in the CCI form, and Data Parameters form (trunked radios only).</p>
<b>conference call</b>	<p>Trunked radios only.</p> <p>A conference call is a <a href="#">group call</a> in which all group members can participate in the conversation. Contrast with <a href="#">broadcast call</a>.</p> <p>In a conference call, all radios in the group are directed to the same <a href="#">traffic channel</a> for the duration of the call. All radios participate freely, as they would for a normal radio-to-radio call.</p>
<b>confidence indicators</b>	<p>Confidence indicators provide feedback to the radio user on how the current operation is proceeding. For example, <a href="#">keypress confidence tones</a> are the tones heard when a keypad key or a function key is pressed and tell the user whether or not an action is permitted.</p>
<b>control channel</b>	<p>In a <a href="#">trunking system</a>, the control channel is used by the <a href="#">site</a> to let the radio units in the site's coverage area know when they can transmit their call information.</p>
<b>control channel acquisition</b>	<p>Trunked radios only.</p>



Control channel [acquisition](#) is the procedure by which a radio that is not currently on a [traffic channel](#) attempts to select a [control channel](#). Control channel acquisition consists of [hunting](#) for a control channel and confirming that any candidate control channels are suitable to acquire.

**control status**

Control status is a T2020 Selcall feature.

A control status is a [status digit](#) that when received, initiates a particular radio operation. For example, when a radio receives a [quiet interrogation](#) status digit, it transmits its [auto acknowledge](#) sequence with its current [status](#) appended without activating the call received indicator.

**conventional channel operation**

A trunked radio can switch between [trunking](#) and conventional modes of operation. In conventional mode, a radio communicates directly with other radios or via a [repeater](#) rather than through the [trunking system](#).

**CPSX dialling**

CPSX dialling is a [dialling scheme](#) designed for use on Chinese networks that use 5-digit interfleet dialling. It is compatible only with other CPSX dialling [trunking systems](#).

Unlike radios using [MPT 1343](#) dialling, radios using CPSX dialling can display the caller's identity for interfleet and interprefix calls.

**CTCSS**

CTCSS (continuous tone controlled squelch system) is a type of [signalling](#) used for segregating groups of users. CTCSS uses subaudible [tones](#) between 67 and 250.3 Hz to identify a group of radio users.

**CTCSS/DCS filter**

The CTCSS/DCS filter removes any [CTCSS](#) or [DCS](#) tones that may be present on the received audio. The filter limits the range of frequencies the radio passes from the incoming signal to the speaker and so in some situations affects signal quality. Filtering can be automatically switched off for channels that do not have CTCSS or DCS.

The CTCSS/DCS filter is enabled in the Subaudible Signalling tab (conventional radios only).

**D**

**data**

See [computer controlled interface](#).

**data codeword**

A data codeword is a 64-bit [codeword](#) that conforms to the requirements of [MPT 1327](#) in which the first bit is set to 0. Data codewords are linked to an [address codeword](#) and supplement the information in the address codeword.

**DCS**

DCS (digital coded squelch) is a type of [signalling](#) used for segregating groups of users. DCS uses subaudible [tones](#) between 10 and 134 Hz to transmit digital data to identify a group of radio users.

DCS codes take the form of a continuously repeating 23-bit digital codeword that represents a user group. Codewords are identified by a three-digit octal number, which forms part of the codeword. The remainder of the codeword includes a sequence of bits derived mathematically from the three-digit code.

When assigning DCS signalling for a channel, it is only necessary to specify the three-digit code. See “[Standard DCS Codes and Their Inverses](#)” on page 115 and “[Non-Standard DCS Codes and Their Inverses](#)” on page 115 for the DCS codes T2000 conventional radios support.

**DCS polarity** DCS signals are susceptible to polarity inversion at various points in the signal path from originator to recipient. On some systems, consistent inversions can be compensated for by forcing the radio to decode the inverse of every codeword.

[Tx](#) and [Rx](#) DCS polarity is set in the Subaudible Signalling form.

**default mode** Default mode is a T2020 feature.

The default mode is the mode the radio enters into once the power-up sequence is complete and after 10 seconds of no user activity.

Possibilities are:

- [channel entry/selection mode](#)
- [DTMF dialling mode](#)
- [Selcall dialling](#)
- status entry mode
- [alphanumeric entry mode](#)
- [user function menu entry mode](#)

No default mode is also an option.

When no default mode has been programmed, the radio powers up in the mode selected when the radio was last on.

Default mode is set in the Specifications form.

**deferred calling** Deferred calling is a Selcall feature.

When the [transmit inhibit](#) conditions are Busy or Mute, a Selcall call cannot be transmitted on a busy channel. When the deferred calling feature is enabled, the call is stored and sent at a random time between 1 and 10 seconds after the channel becomes free.

When a call has been deferred, [scanning](#) is suspended until the call is successfully sent or until the deferred call is cancelled (by pressing any key or switching to another channel).

Deferred calling is enabled in the Selcall Features form for T2020 radios and is always enabled for T2010/T2015 radios, as long as the [Tx Inhibit](#) field is set to Busy or Mute (Transmitter Setup form).

**despatcher** Trunked radios only.

A despatcher is a person who gives official instructions by radio to a [fleet](#).

**despatcher callback request** Trunked radios only.

A despatcher callback request is a call sent to the fleet’s [despatcher](#). The despatcher will then call back the calling radio at a convenient time.

**dialling scheme** Trunked radios only.

The dialling scheme determines how a radio user makes calls to other radios in and outside the [fleet](#), [groups](#) of radios, [PABX](#) extensions and [PSTN](#) numbers. The dialling scheme is the set of numbers a radio user can dial.

T2000 radios support the following dialling schemes:

- [MPT 1343](#)
- [CPSX Dialling](#)
- [Nokia ANN](#)
- [ZVEI](#)
- [Number Presets](#)

<b>do not disturb</b>	<p>Trunked radios only.</p> <p>Do not disturb allows the radio user to ignore incoming calls while still making outgoing calls as usual. Do not disturb can be activated by dialling *49# and can be deactivated by dialling #49#.</p>
<b>double voting</b>	<p>Double voting is a type of <a href="#">voting</a> in which the signal strength of each channel in the group is measured twice.</p>
<b>double voting with signalling</b>	<p>Double voting with signalling is a type of <a href="#">voting</a> in which a channel must have valid signalling before it is made the <a href="#">home channel</a>. The channel's signal strength is measured twice.</p>
<b>DTMF</b>	<p>DTMF is a T2020 or T2040 feature.</p> <p>DTMF (dual tone multiple frequency) is the tone-based system used for the world's telephone networks. A DTMF "tone" consists of a pair of <a href="#">tones</a>, which are sometimes referred to as "touch tones".</p> <p>T2020 radios can encode DTMF tones and make DTMF calls (see <a href="#">DTMF string</a>), but cannot decode and receive DTMF calls.</p> <p>T2040 radios can dial DTMF strings with a DTMF options board fitted. DTMF options are enabled in the Interface Options form.</p>
<b>DTMF call</b>	<p>See <a href="#">DTMF string</a>.</p>
<b>DTMF dialling</b>	<p>The DTMF dialling feature allows the radio user to dial <a href="#">DTMF strings</a> using the numeric keypad or a DTMF microphone.</p>
<b>DTMF dialling mode</b>	<p>DTMF dialling mode is a T2020 feature.</p> <p>In DTMF dialling mode, the user can dial <a href="#">DTMF strings</a>. DTMF dialling mode is available when the <a href="#">Manual Dialling</a> field in the DTMF form is enabled.</p>
<b>DTMF redial</b>	<p>DTMF redial is a T2020 feature.</p> <p>DTMF redial is a feature of <a href="#">DTMF dialling mode</a>. When the radio user enters DTMF dialling mode, the last DTMF string transmitted is displayed. The user can transmit that string by pressing the enter key.</p> <p>DTMF redial is enabled in the DTMF form.</p>

**DTMF string** A DTMF string is a series of DTMF [tone](#) pairs. When defining [DTMF strings](#), the different tones are represented by the characters 0-9, A-D, \* and #. The frequencies used are determined by an internationally accepted standard.

**dual priority scanning** Dual priority scanning is a type of [scanning](#) in which two of the [member channels](#) are designated as [priority channels](#). The priority channels are scanned more often than the other member channels.

**DZVEI** DZVEI is one of the Selcall [tone sets](#) the T2000 Programming Application supports. Note that E is the repeat tone.

Tone : Frequency (Hz)	Tone : Frequency (Hz)
0 : 2200	8 : 1830
1 : 970	9 : 2000
2 : 1060	A : 825
3 : 1160	B : 740
4 : 1270	C : 2600
5 : 1400	D : 885
6 : 1530	E : 2400
7 : 1670	F : 680

## E

**economy mode** Economy mode reduces the radio's power consumption when it is idle. When economy mode is enabled, and there has been no [valid activity](#) on a channel for the duration of the [economy time out](#), the radio enters economy mode. On T2020 and T2040 radios, the [LCD backlighting](#) may dim or switch off when the radio enters economy mode.

The beginning of a transmission may be lost if it is received after a period of inactivity has caused the radio to enter economy mode.

The timeout times for economy mode are set in the Power Saving form. The economy mode backlighting level for T2020 radios is set in the User Selectable form, and for T2040 radios is set in the Power Saving form.

**economy time out** The economy time out sets the time between when [valid activity](#) was last detected on a channel and the start of [economy mode](#).

The economy mode time out with ignition on and off is set in the Power Saving form.

**EEA**

EEA is one of the Selcall [tone sets](#) the T2000 Programming Application supports. Note that E is the repeat tone.

Tone : Frequency (Hz)	Tone : Frequency (Hz)
0 : 1981	8 : 1747
1 : 1124	9 : 1860
2 : 1197	A : 1055
3 : 1275	B : 930
4 : 1358	C : 2400
5 : 1446	D : 991
6 : 1540	E : 2110
7 : 1640	F : 2247

**EIA**

EIA is one of the Selcall [tone sets](#) the T2000 Programming Application supports. Note that E is the repeat tone.

Tone : Frequency (Hz)	Tone : Frequency (Hz)
0 : 600	8 : 1728
1 : 741	9 : 1869
2 : 882	A : 2151
3 : 1023	B : 2433
4 : 1164	C : 2010
5 : 1305	D : 2292
6 : 1446	E : 459
7 : 1587	F : 1091

**emergency call**

For conventional radios, when the emergency call is transmitted, the radio enters [emergency mode](#). An emergency call can be assigned to the auxiliary key (T2020 radios), or to an external device. The Selcall emergency sequence is defined in the Selcall Identity tab. Emergency operation is set up in the Selcall Emergency form (T2020 radios only).

For trunked radios, an emergency call is a call that pre-empt other calls on the [trunking system](#) when there are no free channels. Emergency calls can have a different call time limit than normal calls. An emergency call is dialled

**emergency mode**

Emergency mode is a T2020 Selcall feature, and a T2040 external call feature.

When in emergency mode, the radio transmits an emergency sequence or a call string. The radio can be programmed to then cycle between receiving and transmitting, so that the called party can hear activity near the radio and so decide how to respond. The control head indicators on the radio remain unchanged while in emergency mode.

Emergency operation is set up in the Selcall Emergency form for T2020 radios, and External Calls form for T2040 radios.

**enhanced scanning** Enhanced Scanning is a [T2015](#) radio feature.

When enabled, the radio user can define a temporary scan list using the front panel of the radio. Priority channels can be assigned to the list, as well as designated channels for the [M1] and [M2] keys. The list will be reset to the default either when the radio is switched off, or when the radio is switched on with the PTT pressed.

Enhanced Scanning is enabled in the [Specifications \(Conventional\) Form](#), the temporary list can be read or programmed in the [Enhanced Scan Form](#), and the default scan list is set in the [Channels Form](#).

**ESN** ESN stands for electronic serial number. This number is a unique identifier given to each radio unit by the manufacturer. Radio units may be validated by this number.

## F

**FFSK** FFSK (fast frequency shift keying) is the signalling method employed in trunked radios. Data is represented by 1 cycle of 1200 Hz (logic 1) or 1.5 cycles of 1800 Hz (logic 0) and is transmitted at 1200 baud.

**fleet** Each customer on a trunked [network](#) is assigned their own fleet. This keeps each customer unique so that their activities can be monitored and controlled separately from each other. Each radio unit on the network belongs to their associated customer's fleet.

**FOACSU** FOACSU stands for full off-air call set up. In full off-air call setup, a traffic channel is not allocated for a call until the called party has answered.

**frequency band** The radio's frequency band is the range of frequencies it is capable of transmitting and receiving on.

The frequency band is set in the Specifications form.

## G

**gap** A gap is a pause in the transmission of [tones](#) in a [Selcall sequence](#). When constructing Selcall sequences, a gap is represented by a hyphen (-).

A series of gaps makes up a [gap burst](#).

**gap burst** A gap burst is a series of [gaps](#). The gap burst length is determined by the number of gaps in the burst.

Gap bursts are used to separate [tone bursts](#) in a [Selcall sequence](#).

<b>group</b>	<p>For conventional radios, a group can refer to a <a href="#">scan group</a> or to a group of radios that is the recipient of a Selcall <a href="#">group call</a>.</p> <p>For trunked radios, group refers to one or more radio units that are the recipient of a <a href="#">group call</a>. In <a href="#">MPT 1327</a>, each group is given a unique <a href="#">address</a>, to which radio units subscribe to be part of that group. The maximum number of groups permitted is four for T2030 radios, and 32 for T2035 and T2040 radios.</p>
<b>group call</b>	<p>For conventional radios, a Selcall call can be made to a group of radios by including a <a href="#">group tone</a> in the <a href="#">Selcall sequence</a>. On T2020 radios, a single group tone (G) can be dialled using the * key, and the # key fills the remainder of the sequence with Gs. To make a Selcall group call using the # key, group dialling must be enabled in the Selcall Features form. To make a Selcall group call using the * key, group selective dialling must be enabled in the Selcall Features form.</p> <p>For trunked radios, a group call is a call that involves more than two radios simultaneously. Group calls can only be heard by radios subscribed to the group. Group calls can be <a href="#">conference calls</a> or <a href="#">broadcast calls</a>. Groups are defined in the Radio Unit ID form.</p>
<b>group hold time</b>	<p>Conventional radios only.</p> <p>The group hold time is the pause between when <a href="#">valid activity</a> on a <a href="#">scan group member channel</a> ceases and when <a href="#">scanning</a> resumes.</p> <p>The group hold time is set in the Scan Groups tab.</p>
<b>group select</b>	<p>Trunked radios only.</p> <p>Group select allows the radio user to select a <a href="#">group</a> or group of groups (scan group) from the front panel of T2035 and T2040 radios.</p> <p>Group Select is enabled in the Radio Unit ID form.</p>
<b>group tone</b>	<p>Group tones are a Selcall feature.</p> <p>The group tone, G, acts as a wild card tone and so is equivalent to all of tones 0 to 9, B, C, D or F. For example, when a <a href="#">Selcall sequence</a> containing 123GG for the <a href="#">receiver identity</a> is transmitted, all radios with a five tone <a href="#">Rx decode sequence</a> starting with tones 123 recognise the Selcall sequence, and respond to it.</p> <p>To make a Selcall <a href="#">group call</a> using the keypad, group dialling and group selective dialling must be enabled in the Selcall Features form.</p>
<b>group user programmable</b>	<p>See <a href="#">programmable scanning and voting groups</a>.</p>
<b>GTC</b>	<p>Trunked radios only.</p> <p>GTC stands for go to channel. A GTC message is sent by the control channel as part of the call setup procedure. The GTC tells the radio units involved in the call to switch to the traffic channel designated for the call.</p>

## H

- handshaking** Handshaking refers to the character definitions used to begin and end data flow in CCI ([computer controlled interface](#)) operation. The handshaking characters prevent the loss of data between the radio unit and the computer equipment. Handshaking options are set in the CCI form.
- hidden channel** A hidden channel is a [scan group member channel](#) that is not accessible as an individual [channel](#).  
Hidden channels are enabled in the Scan Groups tab.
- home channel** For [scanning](#), the home channel is the channel in a [scan group](#) on which transmissions are made, unless another channel has been [captured](#). The home channel is the first channel included in the group in the Scan Group Members list.  
For [voting](#), the home channel is the channel that has been determined as having the greatest signal strength. If no channel has been selected, then the home channel is the first channel included in the group in the Scan Group Members list.
- hookswitch** The microphone hookswitch is closed when the microphone button is connected to the earthed microphone clip. Note that if the microphone clip is not earthed, the hookswitch is disabled. To open the hookswitch, remove the microphone from the microphone clip.  
The operation of the hookswitch is affected by the following settings:
- The [Hookswitch Monitor](#) field (Receiver Monitoring form for conventional radios, Conventional Channels form for trunked radios). When this field is checked, opening the hookswitch activates the monitor function.
  - The [Off Hook Scanning](#) field (Channels form for T2010/T2015 radios and the Scan Groups tab for T2020 radios). When this field is checked, scanning continues when the hookswitch is open.
- hunting** Hunting is a procedure used by the radio unit to select an appropriate [control channel](#) to allow a session with a [trunking system](#) to be initiated or continued. The hunting process consists of systematic sampling of the forward [channel](#) frequencies by the radio unit until it selects and confirms one of the forward channels, which together with its paired return channel is an appropriate control channel.  
Types of hunting include:
- [background hunt](#)
  - [comprehensive hunt](#)
  - [normal hunt](#)
  - [preferential hunt](#)
  - [resuming hunt](#)
  - [single channel hunt](#)
  - [vote now](#)



## IJK

<b>ident</b>	The ident is the part of the radio's <a href="#">address</a> that uniquely identifies that radio. In <a href="#">MPT 1327</a> , radios are identified by a three-digit <a href="#">prefix</a> and a four-digit ident. All radios in a <a href="#">fleet</a> usually have the same prefix, but no two radios should have the same ident.
<b>indicator</b>	Indicators provide feedback to the radio user on how the current operation is proceeding and on the operating state of the radio. T2000 radios use combinations of audible and visual indicators.
<b>individual call</b>	Trunked radios only. An individual call is a call from one radio to another. Because individual calls take place on a <a href="#">traffic channel</a> allocated specifically for that call, they cannot be overheard by other radios in the <a href="#">fleet</a> or on the same <a href="#">trunking network</a> . Individual calls are the most common type of <a href="#">trunking</a> call.
<b>interfleet call</b>	Trunked radios only. An interfleet call is a call between two radio units that belong to different <a href="#">fleets</a> .
<b>interfleet group call</b>	Trunked radios only. An interfleet group call is a <a href="#">group call</a> in which participating radios belong to different <a href="#">fleets</a> .
<b>invalid activity</b>	Invalid activity is traffic on a channel that carries <a href="#">signalling</a> that does not match that of the receiving radio.
<b>keypress confidence tones</b>	Keypress confidence tones are <a href="#">confidence indicators</a> that tell the radio user whether or not an action is permitted by emitting a tone whenever a keypad key or function key is pressed. Keypress confidence tones are enabled in the User Selectable form for conventional radios and the Interface Options form for trunked radios.

## L

<b>label</b>	A label is a sequence of up to eight characters that can give the radio user additional information about the radio's current state. For example, a label can be set that indicates which channel is currently selected. In the case where the label stands for a string that is to be transmitted, e.g. for a status message, it is not the <a href="#">status label</a> that is transmitted but rather the <a href="#">status digits</a> . In order for the correct status label to be displayed on the receiving radio, status messages (status digit plus status label) should be set the same for all radios in a fleet.
<b>LCD</b>	T2020 and T2040 radios have a control head LCD (liquid crystal display). In combination with the radio's <a href="#">LED indicators</a> and <a href="#">audible indicators</a> , the display provides the radio user with information on the state of the radio.

**lead in delay** A lead in delay is the delay between when the radio starts transmitting and when the first tones in a sequence are sent. A lead in delay gives the receiver time to prepare to decode the incoming transmission (e.g. time to halt [scanning](#), come to full power or come out of [economy mode](#)).

**LED indicator** The light-emitting diodes on the radio control head assist in displaying the state the radio is in. The [audible indicators](#) and the control head display provide information intended to supplement that provided by the LED.

**low power transmit** The low power transmit feature can be used to change the transmit power from the programmed level to low.

## M

**member channel** Conventional radios only.  
A member channel is a channel that belongs to a [scanning](#) or [voting](#) group.

**monitor** Monitor allows the radio user to override a conventional channel's [signalling](#) and so hear all traffic on a channel.  
Note that monitor is not permitted in some countries.

**MPT 1327** MPT 1327 is a radio unit signalling standard published by the United Kingdom Department of Trade and Industry that describes the signalling standard for trunked private land mobile radio systems.

**MPT 1343** MPT 1343 is a performance specification standard published by the United Kingdom Department of Trade and Industry that describes the system interface specification for radio equipment to be used with commercial trunking networks operating in Band III, sub-bands 1 and 2.  
MPT 1343 also refers to the set of numbers a radio user can dial (the [dialling scheme](#)).

**mute** A mute controls the circumstances under which a received signal is passed to the radio's speaker. When a mute is active, the radio's speaker only unmutes under certain conditions, determined by the type of [signalling](#) operating on a [channel](#).

**mute received audio** Mute received audio is part of the T2015/T2020 Selcall [emergency mode](#). When mute received audio is enabled, the radio's [mute](#) remains active while in emergency mode and so the radio does not broadcast noise that may draw attention in an emergency situation.  
Mute received audio is enabled in the Selcall Emergency form.

## N

**NATEL** NATEL is one of the Selcall [tone sets](#) the T2000 Programming Application supports. Note that E is the repeat tone.

Tone : Frequency (Hz)	Tone : Frequency (Hz)
0 : 1633	8 : 1336
1 : 631	9 : 1477
2 : 697	A : 1995
3 : 770	B : 571
4 : 852	C : 2205
5 : 941	D : 2437
6 : 1040	E : 1805
7 : 1209	F : 2694

**NDD** NDD stands for network dependent data. NDD is an [MPT 1343](#) term and is a means of identifying specific [control channel](#) transmissions that originates within a [network](#).

**network** A network is a number of interconnected [trunking systems](#).

**non-captured priority sample timer** The value of the non-captured priority sample timer determines how often [priority channels](#) are scanned when there is no [captured](#) channel. The duration of the non-captured priority sample timer is set in the Scan Groups tab.

**Nokia ANN** Nokia ANN (Algorithmic Network Numbering) is a [dialling scheme](#) designed for use on Nokia Actionet networks. It differs from [MPT 1343](#) in the way it divides up [fleets](#). Nokia ANN numbering reduces the number of digits that must be dialled for calls between fleets.

**non-prescribed data call** A non-prescribed data call is a data call of a non-MPT format that requires the use of a traffic channel.

**normal dialling** Conventional radios only. When a [DTMF string](#) is dialled, the string is either transmitted as each individual key is pressed (normal dialling) or in its entirety once the enter key is pressed ([buffered dialling](#)). The DTMF dialling type is set in the DTMF form.

**normal hunt** A normal hunt is carried out as part of the [control channel acquisition](#) procedure. A normal hunt covers all [channel](#) numbers likely to be used as [control channels](#) on the selected [network](#). For a normal hunt, the radio will undergo [registration](#) on a new control channel, if necessary.

The channels that will be searched as part of the normal hunt procedure are defined in the [Normal Hunt Channels Grid](#) ([Hunting Parameters](#) form). If the radio fails to find a suitable control channel among these channels, it will, if programmed, carry out a [comprehensive hunt](#).

**NPD** See [non-prescribed data call](#).

**number presets** Number presets is a [dialling scheme](#) based on the [MPT 1343](#) dialling scheme. Number presets, however, limits the calls a radio can make to those programmed as preset calls at radio programming time. The calls programmed can be any number the radio user would normally be able to dial using [MPT 1343](#) numbering.

## O

**off-air** Trunked radios only.  
The term off-air is used to describe the call setup procedure used when the channels are setup and allocated even though the called party has not yet answered. This usually occurs when it is known that the called party is available.

**on/off volume control** The on/off/volume control is the round knob on the control head of T2000 radios.

**one touch call** One touch calls are a T2020 feature.  
The auxiliary key on a T2020 radio can be set to transmit a predefined one touch call. This call can be a Selcall or DTMF call.  
The auxiliary key one touch call is set in the Key Settings form.

## P

**PABX** PABX stands for private automatic branch exchange. A [trunking system](#) can be connected to a PABX and so radios using that system can make calls to and receive calls from [PABX extensions](#).

**PABX extension** A PABX extension is a line on a [PABX](#) system.

**polling** Polling is the sampling of [member channels](#) to measure their signal strength when the radio is [voting](#) a [scan group](#).

**polling interval** The polling interval is how often the [member channels](#) in a [voting](#) group are sampled (“polled”) for greatest signal strength.

**power-up message** The power-up message is the message displayed by T2020 and T2040 radios after the radio is turned on.  
The power-up message is programmable (Specifications form).

<b>preferential hunt</b>	<p>A preferential hunt is carried out as part of the <a href="#">control channel acquisition</a> procedure. A preferential hunt covers all <a href="#">channel</a> numbers likely to be used as <a href="#">control channels</a> on the selected <a href="#">network</a>. For a preferential hunt, the radio will only acquire a control channel for which a preference exists.</p> <p>Preference data is defined in the <a href="#">Acquisition Data</a> form.</p>
<b>prefix</b>	<p>In <a href="#">MPT 1327</a>, radios are identified by a three-digit prefix and a four-digit <a href="#">ident</a>. Radio units in a <a href="#">fleet</a> usually have the same prefix.</p>
<b>priority call</b>	<p>For T2020 radios, a priority call is a <a href="#">Selcall sequence</a> that has a priority <a href="#">control status</a> appended. When the receiving radio decodes the priority <a href="#">status digit</a>, it alerts the user that a priority call has been received. This alert does not end after a period of time, the user must either answer the call, or clear it down using any of the control head keys. The priority call control status is set in the <a href="#">Selcall Status form</a>.</p> <p>For trunked radios, a priority call is a call that pre-empt other calls on the <a href="#">trunking</a> system when there are no free channels. Priority calls do not, however, pre-empt <a href="#">emergency calls</a>.</p>
<b>priority channel</b>	<p>Conventional radios only.</p> <p>A priority channel is a <a href="#">scan group member channel</a> that is scanned more often than the other member channels.</p>
<b>priority sample timers</b>	<p>Conventional radios only.</p> <p>The <a href="#">captured priority sample timer</a> and <a href="#">non-captured priority sample timer</a> determine how often <a href="#">priority channels</a> in a <a href="#">scan group</a> are scanned.</p>
<b>priority scanning</b>	<p>Conventional radios only.</p> <p>Priority scanning is a type of <a href="#">scanning</a> in which one of the <a href="#">member channels</a> is designated the <a href="#">priority channel</a>, which is scanned more often than the other member channels.</p>
<b>programmable channel signalling</b>	<p>Programmable channel signalling is a T2020 feature.</p> <p>The programmable channel signalling feature allows the radio user to change the <a href="#">subaudible signalling</a> used on a channel.</p>
<b>programmable scanning and voting groups</b>	<p>Conventional radios only.</p> <p>The programmable <a href="#">scanning</a> and <a href="#">voting</a> groups feature allows the radio user to change the mix of <a href="#">channels</a> that belong to scanning and voting groups.</p>
<b>programming database</b>	<p>The programming database is the information that is altered using the T2000 Programming Application.</p> <p>When the Radio &gt; <a href="#">Read</a> command is selected, the radio's programming database is read and the information in it is loaded into the fields and forms in the programming application. When the Radio &gt; <a href="#">Program</a> command is selected, the radio's programming database is overwritten with the information altered in the programming application.</p>





**PSTN** PSTN stands for public switched telephone network, the public telephone network on which subscribers own or rent tethered communications devices (telephones, facsimiles, modems) as opposed to untethered communications devices (radio telephones, cellular phones). A [trunking system](#) can be connected to the PSTN and so radios using that system can make calls to and receive calls from PSTN numbers.

**PTT key** The PTT (press-to-talk) key is the key pressed to transmit. The radio cannot receive while the PTT is pressed.

For conventional radios, the amount of time the radio is permitted to transmit is limited by the [transmit timer](#). When the transmit timer expires, the radio emits a series of warning tones before returning to the receive state.

Once the transmit timer expires, the radio may be prevented from transmitting for the duration of the [transmit lockout](#) timer.

**PTT as shift key** The PTT as shift key feature is part of the T2020 [DTMF dialling](#) function. If the user wishes to dial tones A to D, the PTT can be used as a “shift” key in conjunction with the numeric keypad. For example:

- PTT +  = A
- PTT +  = B
- PTT +  = C
- PTT +  = D

PTT as shift key is enabled in the DTMF form.

**PZVEI** PZVEI is one of the Selcall [tone sets](#) the T2000 Programming Application supports. Note that E is the repeat tone.

Tone : Frequency (Hz)	Tone : Frequency (Hz)
0 : 2400	8 : 2000
1 : 1060	9 : 2200
2 : 1160	A : 970
3 : 1270	B : 810
4 : 1400	C : 2800
5 : 1530	D : 885
6 : 1670	E : 2600
7 : 1830	F : 680

## Q

**quiet state** Quiet state is the state the radio is in when [monitor](#) is inactive and the radio user does not have to listen to traffic that is not intended for them.

**quiet status interrogation**

Quiet status interrogation is a T2020 Selcall feature.

The quiet status interrogation feature allows a radio to send a [control status](#) to another radio requesting that the radio transmit its current status without alerting the radio user. Upon receiving the control status, the called radio responds by transmitting its [auto acknowledge](#) sequence with its current [status](#) appended.

The quiet interrogation control status is set in the Selcall Status form.

**R**

**radio identity**

For conventional radios, when a radio is operating on a [Selcall system](#), it can have a unique identity assigned. This identity is defined by the [Rx decode sequence](#). The radio's [Rx decode sequences](#) are set in the Selcall Identity tab.

For trunked radios, each radio operating on a [trunking system](#) is assigned its own unique identity. How that identity is assigned depends on the [dialling scheme](#). In [MPT 1327](#), a radio's identity is made up of a three-digit [prefix](#) and a four-digit [ident](#).

**radio monitor reset**

Radio monitor reset is a Selcall feature.

When the radio receives a radio monitor reset sequence and the radio monitor reset function has been enabled, the radio deactivates [monitor](#), [squelch override](#) and/or emergency cycling, if they are active.

**receive (Rx) format**

The receive (Rx) format is a Selcall feature.

The receive format defines the format all incoming [Selcall sequences](#) must follow in order to be correctly decoded by the receiving radio. The receive format should be the same for all radios using a particular [Selcall system](#).

If the receive format has an [S burst](#), it must match the S burst for the Selcall system's [transmit \(Tx\) format](#).

The receive format for the [Selcall system](#) is set in the Selcall Identity tab.

**receive (Rx) frequency**

The receive frequency is the frequency that a radio is currently tuned to. For conventional radios, the receive frequency for each channel is set in the Channels form. For trunked radios, the receive frequency for each channel is set in the [Trunked Channel Blocks](#) form and the [Conventional Channels](#) form.

**receive signalling**

The receive signalling is the [signalling](#) that must accompany incoming transmissions in order for the radio to recognise the signal as [valid](#) and so open the radio's [mute](#). For conventional radios, the receive signalling for each channel is set in the Channels form. For trunked radios, the receive signalling for each channel is set in the [Conventional Channels](#) form.

**received call queuing**

See [call queuing](#).

<b>receiver identity</b>	In a <a href="#">Selcall sequence</a> , the receiver identity is the part of the sequence that identifies the radio the sequence is intended for. In the <a href="#">transmit (Tx) format</a> and <a href="#">receive (Rx) format</a> , the receiver identity is represented by the character R, and so this part of a sequence is known as the R burst.
<b>registration</b>	Trunked radios only. A radio unit must let the <a href="#">trunking system</a> know its current location, especially if the radio unit roams throughout the <a href="#">network</a> . Knowledge of its location allows for an efficient call setup process when the radio unit is called. A radio unit will attempt to register if the area code of the new <a href="#">site's</a> system identity code is different to that of the previous site.
<b>repeat tone</b>	Repeat tones are a Selcall feature. A repeat tone is used to ensure that <a href="#">Selcall sequences</a> are correctly decoded by a receiving radio. When two adjacent tones in a Selcall sequence are the same tone, the repeat tone is substituted for the second occurrence of the duplicated tone. The repeat tone is always tone E.
<b>repeater</b>	A repeater receives a radio signal and retransmits it. Use of a repeater increases the coverage area of a two-way radio system and ensures more reliable performance in areas where signals are reflected or attenuated by buildings or terrain. In a repeater-based system, the radio's transmit frequency is the frequency the repeater is listening on, and the radio's receive frequency is the frequency the repeater rebroadcasts signals on.
<b>repeater identity</b>	In a <a href="#">Selcall sequence</a> , the repeater identity is the part of the sequence that the radio transmits so that the <a href="#">repeater</a> recognises the radio as having access to the repeater. In the <a href="#">transmit (Tx) format</a> , the repeater identity is represented by the character B, and so this part of a sequence is known as the B burst. If the transmit format includes a repeater burst, it must come before all other bursts.
<b>repeater talkaround</b>	Conventional radios only. Repeater talkaround allows the radio user to bypass <a href="#">repeater</a> operation and so communicate directly with other radios. While repeater talkaround is active, all transmissions are made on the receive frequency programmed for the channel. Repeater talkaround may be required if the radio is operating outside the range of the repeater. Note that repeater talkaround is not permitted in some countries. Repeater talkaround is enabled in the Transmitter Setup form.
<b>resuming hunt</b>	A resuming hunt is carried out as part of the <a href="#">control channel acquisition</a> procedure. When a call is cleared down and a radio leaves a <a href="#">traffic channel</a> , a resuming hunt allows the radio to resume the <a href="#">control channel</a> on which it was last confirmed prior to going to the traffic channel.
<b>reverse tone burst</b>	Conventional radios only.



Reverse tone bursts can be used when [CTCSS subaudible signalling](#) is used. When reverse tone bursts are enabled, the phase of the generated tones is reversed for a number of cycles just before transmission ceases, which can increase the speed of receiver shutdown in some repeaters and associated equipment.

For conventional radios, the phase reversal occurs after any [ANI](#) transmission. The reverse tone burst duration is set in the Subaudible Signalling form.

**revive**

See [stun and revive](#).

**roaming**

Trunked radios only.

When a radio unit moves around the [network](#), it reaches a point where the signal strength is approaching the preprogrammed lower limit. At this point it will automatically search for a better signal. Once it has received a suitable signal from a valid [site](#), it will register on the new site.

**Rx**

Rx is an abbreviation for receive.

**Rx decode sequence**

The Rx decode sequence is a Selcall feature.

The Rx decode sequence is the radio's unique identity on a [Selcall system](#). When the radio's Rx decode sequence is decoded as the [receiver identity](#) in an incoming [Selcall sequence](#), the radio recognises the sequence as intended for it and responds appropriately.

T2015/T2020 radios operating on a Selcall system can have one or two Rx decode sequences assigned. T2010 radios only have one Rx decode sequence assigned. In addition to tones 0 to 9, B, C, D or F, a **\*** wild card tone can be used in the Rx decode sequence (T2015/T2020 radios only). This means that a radio that has an Rx decode sequence of 456\*\* responds to all call sequences with a receiver identity five tones long starting with 456.

## S

**scan group**

For conventional radios, a scan group is a group of 2 to 16 [channels](#). Each scan group [member channel](#) is routinely sampled for activity ([scanning](#)) or greatest signal strength ([voting](#)). Scan groups are set up in the Scan Groups form.

For trunked radios, a scan group is a collective group of groups (\*\*\*) on the T2040 display), that is regularly sampled for activity. Groups belong to the scan group when they are either Scan or Scan+Selectable in the [Group Membership Grid](#) (Radio Identity form).

**scan hold time**

The scan hold time is the pause between when [valid activity](#) on a [scan group member channel](#) ceases and when [scanning](#) resumes.

The scan hold time is set in the Channels form.

**scanning**

Scanning is the systematic sampling of a group of channels (a [scan group](#)) for [valid activity](#). There are two variations of normal scanning: [priority scanning](#) and [dual priority scanning](#).

<b>SDM</b>	<p>T2040 radios only.</p> <p>A short data message is a message that carries more data than a status message but still does not require an audio channel. The user data is contained in the signalling between the site and the radio unit. Short Data Messages are enabled in the Data Parameters form.</p>
<b>Selcall</b>	<p>Selcall stands for “selective calling”, which is a <a href="#">signalling</a> system that uses sequences of audible <a href="#">tones</a> to isolate calls intended for specific radios. Each radio operating on a <a href="#">Selcall system</a> can have a unique identity assigned. Also known as Selcall multi-tone.</p>
<b>Selcall dialling</b>	<p>Selcall dialling is a T2020 feature.</p> <p>Using Selcall dialling, the user can dial <a href="#">Selcall sequences</a> using the keypad.</p>
<b>Selcall mute</b>	<p>When the Selcall mute is enabled, the radio only unmutes when a valid <a href="#">Selcall</a> identity is received. The radio user cannot initiate calls using the PTT unless <a href="#">monitor</a> is active, but can make Selcall calls using the call key (T2010/T2020), or auxiliary key (T2020).</p> <p>Selcall Muting is enabled in the Selcall Setup tab.</p>
<b>Selcall sequence</b>	<p>A Selcall sequence is a series of <a href="#">tones</a> and <a href="#">gaps</a> that for a simple <a href="#">Selcall system</a> represents the identity of a radio (the <a href="#">receiver identity</a>). A Selcall sequence can also contain the identity of the calling radio (the <a href="#">caller identity</a>), the <a href="#">repeater identity</a> and the caller’s current activity (<a href="#">status</a>).</p>
<b>Selcall system</b>	<p>A Selcall system is the call sequence formats and tone options the radios on that system must use to communicate with one another.</p>
<b>selective system</b>	<p>A selective system is one that isolates groups of users on a system by using some form of selective calling e.g. Selcall.</p>
<b>short data message</b>	<p>See <a href="#">SDM</a>.</p>
<b>signal programming mode</b>	<p>Signal programming mode is part of the <a href="#">programmable channel signalling</a> feature. In signal programming mode, the radio user can change a channel’s subaudible signalling.</p>
<b>signalling</b>	<p>Signalling is non-voice coding on a <a href="#">channel</a> for the purpose of identifying parties and segregating groups of users. If a radio receives signalling that matches that programmed for the radio, the signalling is said to be valid and the radio’s <a href="#">mute</a> opens. Otherwise, the transmission is ignored and the radio remains silent, although the radio’s channel busy indicator is activated. See <a href="#">CTCSS</a>, <a href="#">DCS</a> and <a href="#">Selcall</a>.</p>
<b>single channel hunt</b>	<p>Trunked radios only.</p> <p>A single channel hunt is carried out as part of the <a href="#">control channel acquisition</a> procedure. A single channel hunt occurs when the <a href="#">trunking system controller</a> directs a radio to a specific <a href="#">control channel</a>.</p>

<b>site</b>	A site consists of a control unit, a <a href="#">control channel</a> and one or more <a href="#">traffic channels</a> . A number of connected sites make up a <a href="#">trunking system</a> .
<b>site select</b>	Trunked radios only. The site select feature allows the radio user to specify the <a href="#">control channel</a> the radio must acquire. The site select feature overrides the radio's normal <a href="#">acquisition</a> processes. Site Select is enabled in the Hunting Parameters form.
<b>squelch</b>	The squelch feature ensures that the radio's speaker only unmutes when an intelligible signal is received. A signal is considered intelligible when it is strong enough to exceed a predetermined <a href="#">squelch threshold</a> .
<b>squelch override</b>	Squelch override allows the user to disable the radio's <a href="#">squelch</a> and so hear all activity on a channel, including noise. For conventional radios, squelch override is enabled in the Receiver Monitoring form.
<b>squelch threshold</b>	The squelch threshold is the level the signal must reach before it is regarded as intelligible and the radio's <a href="#">mute</a> is opened.
<b>status</b>	On conventional systems, status is a <a href="#">Selcall</a> feature. Status signalling is typically used to report job status to a fleet dispatcher. Numerical <a href="#">status digits</a> are assigned some meaning in the fleet operation context, which must be understood by all parties. In some systems, a status label or alphanumeric mnemonic is also defined to make status selection and recognition easier for users. Conventional radios have a second type of status, <a href="#">control status</a> , which when received, initiate a particular radio operation. Control status need not be associated with a <a href="#">status label</a> .
<b>status digit</b>	A status digit is the data transmitted to send a <a href="#">status</a> message. On conventional systems, the status digit is the part of the <a href="#">Selcall sequence</a> that identifies the current activity of the radio transmitting the sequence. In the <a href="#">transmit (Tx) format</a> and <a href="#">receive (Rx) format</a> , the status digit is represented by the character S, and so this part of a sequence is known as the S burst. On trunking systems, the status digit will be between 0 and 31. Because of the brevity of the message, no audio channel is used. All the required information can be transferred in the signalling between the <a href="#">network</a> and the radio unit.
<b>status label</b>	A status label is a <a href="#">label</a> (alphanumeric mnemonic) that is associated with a particular <a href="#">status digit</a> . If a receiving radio has been programmed with a status label that corresponds to the message transmitted, it displays that label, which is why it is important that all radios in a <a href="#">fleet</a> are programmed with the same status labels.

## stun and revive

For conventional radios Stun and revive is a T2020 Selcall feature. At radio programming time, two [control status](#) can be assigned, one to stun the radio, which makes it inoperable, and the other to revive the radio, which returns it to a usable state. The stun and revive control status values are set in the Selcall Status form.

On trunking systems, a “stun” message can be sent from the [network](#) to a radio and will render the radio inoperable. The radio remains in communication with the [trunking system controller](#) but cannot be used to send or receive calls. A “revive” message sent by the network will return the radio to normal operation.

## subaudible signalling

Subaudible signalling is [signalling](#) that is at the bottom end of the range of audible frequencies. T2010/T2015/T2020 radios support [CTCSS](#) and [DCS](#) subaudible signalling.

## SYNC

In [MPT 1327](#) and [MPT 1343](#), SYNC refers to the [control channel](#) codeword synchronisation sequence.

## SYS

In [MPT 1327](#) and [MPT 1343](#), SYS refers to the system identity code of the transmitting system. Values of SYS which result in the production of the [control channel](#) codeword synchronisation sequence, SYNC, in any part of the 48 information bits of the [CCSC](#) are not permitted.

# T

## T2010

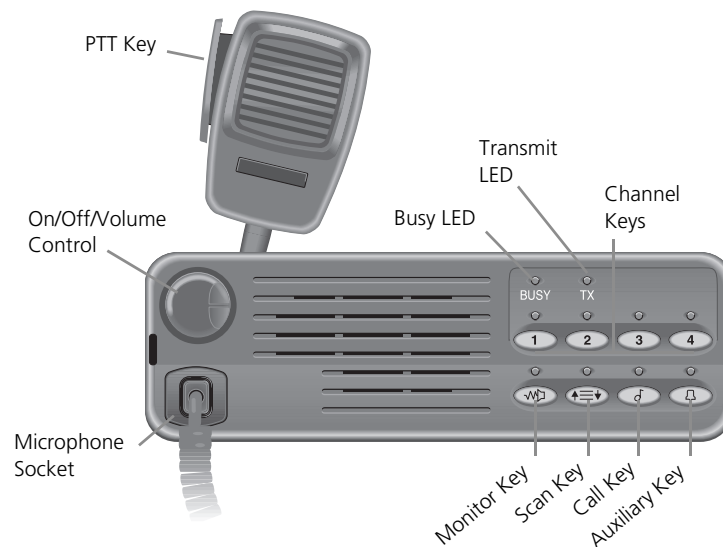

**T2015**

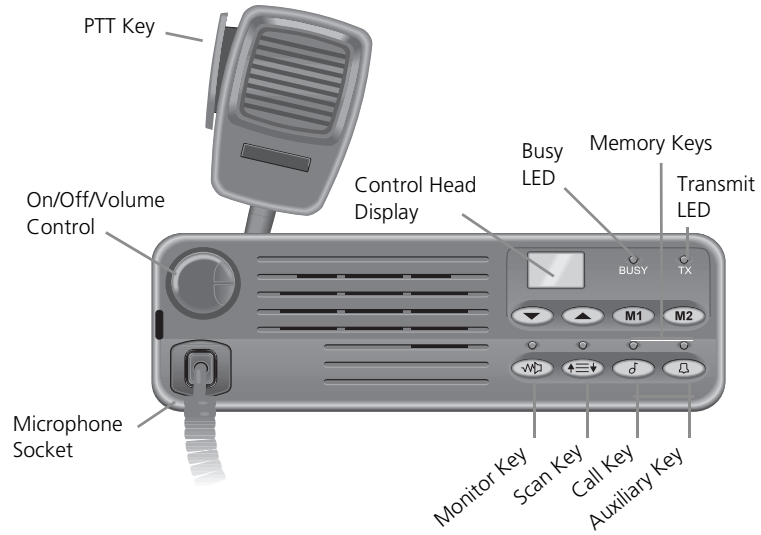

**T2020**

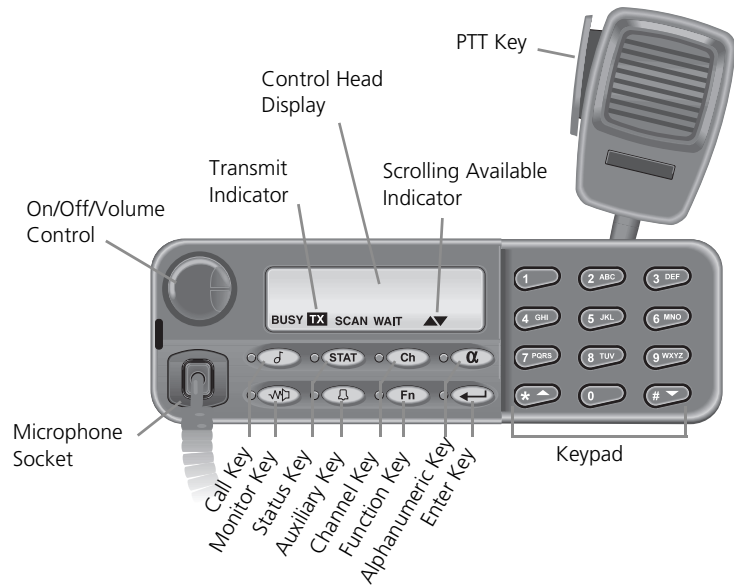

**T2030**

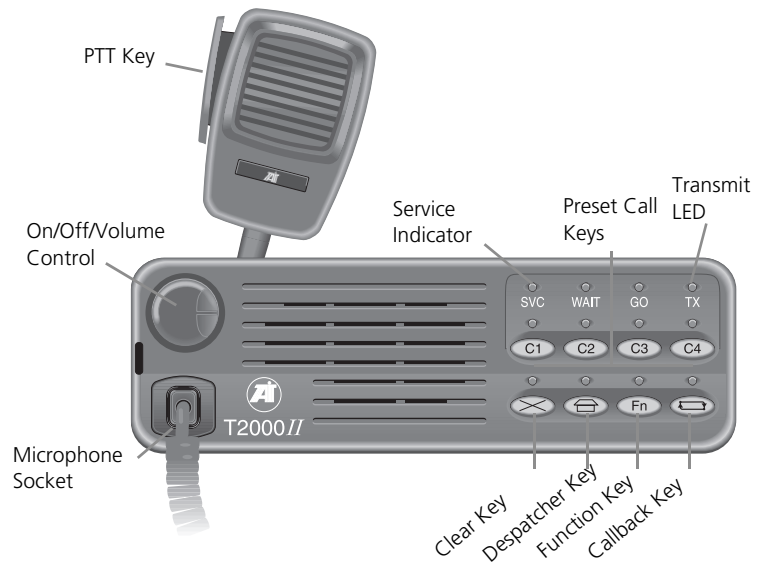

## T2035

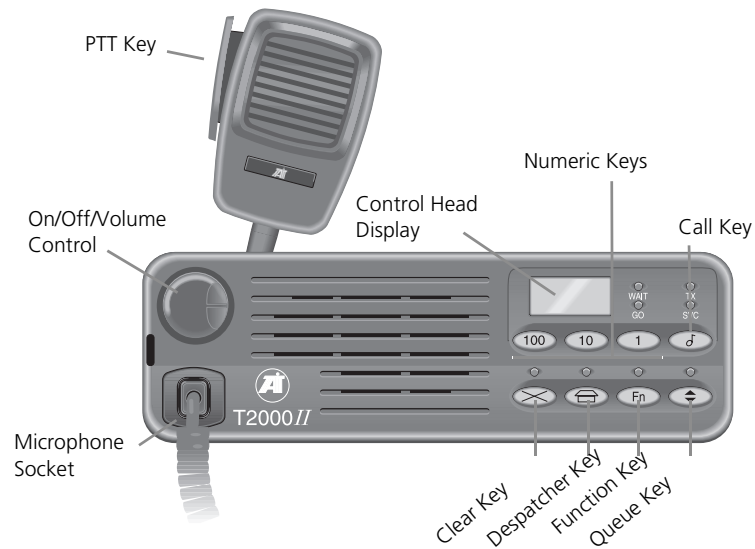

## T2040

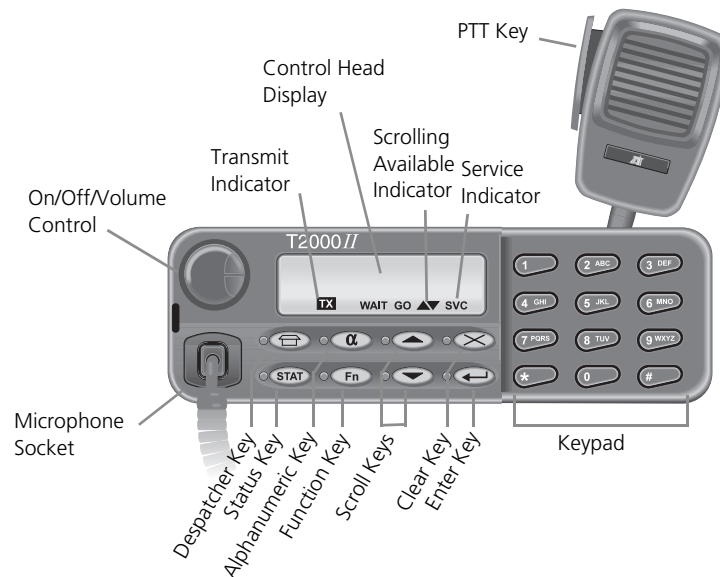

### third tone monitor reset

Third tone monitor reset is a T2020 Selcall feature.

The [monitor](#) and [squelch override](#) are deactivated when the first three tones of the [receiver identity](#) for an incoming [Selcall sequence](#) match the first three tones of one of the radio's [Rx decode sequences](#).

Third tone monitor reset is enabled in the Selcall Features form.

### time-out

Trunked radios only.

Time-out is when a time limit has been reached and the active call is terminated as a result.

### toggle

The term toggle is used to describe the switching between two states.

### tone

A tone is a sound wave of a particular frequency.

For CTCSS and DCS, the tone is transmitted continuously as long as the radio is transmitting. For [Selcall sequences](#) and [DTMF strings](#), the transmit time of each tone is programmable (see [tone duration/period](#)).

When constructing [Selcall sequences](#), different tones are represented by the characters 0 to 9, B, C, D, E, F or G. A series of tones makes up a [tone burst](#). The frequencies used for tones 0-9 and B-F are dependent upon the [tone set](#).

When defining [DTMF strings](#), the different tones are represented by the characters 0-9, A-D, \* and #. The frequencies used are determined by an internationally accepted standard.

#### **tone blanking**

Tone blanking is a Selcall feature.

Tone blanking blanks out the [tones](#) of a received [Selcall sequence](#) so that the user does not hear them. The user may, however, hear the first few tones.

The radio's [Rx decode sequences](#) are set in the Selcall Identity tab.

Tone blanking is enabled in the Selcall Setup tab.

#### **tone burst**

A tone burst is a series of [tones](#) in a [Selcall sequence](#). A burst can correspond to a particular piece of information, as follows:

- [receiver identity](#) (R burst),
- [caller identity](#) (C burst),
- [repeater identity](#) (B burst) and
- [status](#) (S burst).

For example, the R burst defines the receiver identity and can be up to eight tones long. An R burst of five tones would be defined in the Tx and Rx Formats as RRRRRR. For a Selcall sequence that places a call to radio 12345, the R burst would be 12345.

How long a tone burst lasts is determined by the [tone duration/period](#) and the number of tones in the burst. Tone bursts are usually, but not always, separated by a [gap burst](#).

#### **tone duration/ period**

The tone period, or tone duration in the case of DTMF, is how long a tone is transmitted. For example, if the tone period for a Selcall sequence is 10 ms, then a [tone burst](#) of three tones lasts for 30 ms.

For [Selcall sequences](#), the tone period is set in the Selcall Setup tab. For [DTMF strings](#), the tone duration is set in the DTMF form.

#### **tone set**

The tone set is the set of frequencies represented by the characters 0-9 and A-F used to make up [Selcall sequences](#).

There are a number of internationally accepted standard tone sets available. There is a finite number of frequencies available to represent the various characters in a Selcall sequence; it is the frequencies used and their order that distinguishes one tone set from another.

The T2000 Programming Application supports the following tone sets: [CCIR](#), [EIA](#), [EEA](#), [ZVEI-I](#), [ZVEI-II](#), [ZVEI-III](#), [PZVEI](#), [NATEL](#) and [DZVEI](#).

The tone set for the [Selcall system](#) is set in the Selcall Setup tab.

#### **traffic**

Traffic is an intelligible signal on a [channel](#) that exceeds the radio's [squelch threshold](#).

<b>traffic channel</b>	<p>The traffic channel is the <a href="#">channel</a> on a <a href="#">trunking system</a> to which parties participating in a call are directed for the duration of the call. When the call ends, the traffic channel is returned to the pool of channels for use in a new call.</p>
<b>transmit (Tx) format</b>	<p>The transmit (Tx) format is a Selcall feature.</p> <p>The transmit format defines the format all outgoing <a href="#">Selcall sequences</a> must follow in order to be correctly decoded by other radios using the same <a href="#">Selcall system</a>. The transmit format should be the same for all radios using a particular Selcall system.</p> <p>The transmit format is set in the Selcall Identity tab.</p>
<b>transmit (Tx) frequency</b>	<p>The transmit frequency is the frequency that all outgoing transmissions are made on.</p> <p>For conventional radios, the transmit frequency for each <a href="#">channel</a> is set in the Channels form. For trunked radios, the transmit frequency for each <a href="#">channel</a> is set in the <a href="#">Trunked Channel Blocks</a> form and the <a href="#">Conventional Channels</a> form.</p>
<b>transmit inhibit</b>	<p>The transmit inhibit feature determines under what conditions a press of the PTT results in the radio not transmitting. This feature can prevent transmissions that may interrupt other users on the channel.</p> <p>The radio can be prevented from transmitting whenever there is activity on the <a href="#">channel</a>, whether it is <a href="#">valid</a> or <a href="#">invalid</a> (Busy option), or whenever there is invalid activity on a channel (Mute option).</p> <p>For conventional radios, the conditions under which transmission is inhibited are set in the Tx Inhibit field (Transmitter Setup form). For trunked radios, the conditions under which transmission is inhibited during <a href="#">conventional channel operation</a> are set in the <a href="#">Conventional Channels form (Tx Inhibit On Busy field)</a>.</p>
<b>transmit lockout</b>	<p>Conventional radios only.</p> <p>The transmit lockout feature prevents the radio from transmitting once the <a href="#">transmit timer</a> has expired.</p> <p>How long transmission is locked out is set in the Transmitter Setup form.</p>
<b>transmit signalling</b>	<p>The transmit signalling is the <a href="#">signalling</a> that accompanies all outgoing transmissions made.</p> <p>The transmit signalling for each <a href="#">channel</a> is set in the Channels form (conventional radios) or Conventional Channels form (trunked radios).</p>
<b>transmit timer</b>	<p>The transmit timer determines the longest continuous transmission permitted by a radio. When the transmit timer expires, the radio emits a series of warning tones before returning to the receive state.</p> <p>For conventional radios, how long the radio can transmit continuously is set in the <a href="#">Transmit Timer Duration</a> field (Transmitter Setup form).</p>
<b>trunked channel block</b>	<p>A trunked channel block is a set of equally spaced channels on which a <a href="#">trunking system</a> operates.</p>



<b>trunking</b>	Trunking is a radio communications system that dynamically shares a number of communications <a href="#">channels</a> among a large number of users. This ensures equal channel loading and permits significantly higher loading per channel than found in conventional systems.
<b>trunking system</b>	The term trunking system refers to the equipment required to provide the <a href="#">trunking</a> communication facilities at one location.
<b>TSC</b>	See <a href="#">trunking system controller</a> .
<b>trunking system controller</b>	In <a href="#">MPT 1327</a> the trunking system controller (TSC) is the central intelligence necessary to enable the <a href="#">trunking system</a> to function. The TSC communicates with all radios on the <a href="#">network</a> via the <a href="#">control channel</a> .
<b>Tx</b>	Tx is an abbreviation for transmit.

## UVW

<b>user function menu entry mode</b>	<p>User function menu entry mode is a T2020 feature.</p> <p>In user function menu entry mode, the user can customise radio options. This mode is available under the following conditions:</p> <ul style="list-style-type: none"> <li>■ a function is selected to be in the user menu (at least one In User Menu box checked in the User Selectable form)</li> <li>■ a scan group is set to be user programmable (Scan Group Members tab)</li> <li>■ <a href="#">call queuing</a> is enabled (Selcall Features form) and a call is queued</li> <li>■ <a href="#">programmable channel signalling</a> presets are programmed to allow the user to change the channel's subaudible signalling</li> </ul>
<b>valid activity</b>	Valid activity is traffic on a channel that carries <a href="#">signalling</a> that matches that programmed for the receiving radio. The radio's <a href="#">mute</a> opens upon detecting valid activity.
<b>variable status</b>	<p>Variable status is a T2020 Selcall feature.</p> <p>The <a href="#">S burst</a> of a <a href="#">Selcall sequence</a> can be programmed with a V. When the sequence is transmitted, the <a href="#">status digit</a> included corresponds to the status identity last selected in status entry mode.</p>
<b>vote now</b>	<p>Trunked radios only.</p> <p>Vote now is carried out as part of the <a href="#">control channel acquisition</a> procedure. Some <a href="#">trunking systems</a> use a vote now BCAST codeword to help the radio find the best <a href="#">control channel</a>. When the radio receives a vote now BCAST codeword, the radio will switch to the channel specified by the system and monitor its RSSI level. If the RSSI on the new channel is not greater than the current control channel by a particular value, the radio will return to the current control channel. Otherwise it will switch to the control channel specified by the trunking system.</p>

**voting** Conventional radios only.  
 Voting is the systematic sampling of a group of [channels](#) (a [scan group](#)) for the channel with the greatest signal strength. There are three variations of normal voting: [voting with signalling](#), [double voting](#) and [double voting with signalling](#).

**voting with signalling** Voting with signalling is a type of [voting](#) in which a channel must have valid signalling before it is made the [home channel](#).

## XYZ

**ZVEI** Trunked radios only.  
 ZVEI is a [dialling scheme](#) based on the [MPT 1343](#) dialling scheme. The ZVEI dialling scheme is used on Regionet 43 networks.

**ZVEI-I, ZVEI-II, ZVEI-III** Conventional radios only.  
 ZVEI-I, ZVEI-II and ZVEI-III are among the Selcall [tone sets](#) the T2000 Programming Application supports.

**ZVEI-I** Note that E is the repeat tone.

Tone : Frequency (Hz)	Tone : Frequency (Hz)
0 : 2400	8 : 2000
1 : 1060	9 : 2200
2 : 1160	A : 2800
3 : 1270	B : 810
4 : 1400	C : 970
5 : 1530	D : 885
6 : 1670	E : 2600
7 : 1830	F : 680

**ZVEI-II**

Note that E is the repeat tone.

<b>Tone : Frequency (Hz)</b>	<b>Tone : Frequency (Hz)</b>
0 : 2400	8 : 2000
2 : 1060	9 : 2200
3 : 1160	A : 885
4 : 1270	B : 825
5 : 1400	C : 740
6 : 1530	D : 680
7 : 1670	E : 970
8 : 1830	F : 2600

**ZVEI-III**

Note that E is the repeat tone.

<b>Tone : Frequency (Hz)</b>	<b>Tone : Frequency (Hz)</b>
0 : 2400	8 : 2000
1 : 1060	9 : 2200
2 : 1160	A : 885
3 : 1270	B : 810
4 : 1400	C : 2800
5 : 1530	D : 680
6 : 1670	E : 970
7 : 1830	F : 2600



# Index

---

## Symbols

- # key 40
- # tone 55
- \* key 40
- \* tone 34, 44, 55
- 1, 10 and 100 keys 99
- 25-pin serial connector 3
- 5 digit access string 101
- 5 Digit Lookup form 100

## A

- abbreviated dialling 102, 127
- abbreviated dialling limit 103
- about 12
- access level 6, 11, 68, 74, 83, 89, 131
- access number 87
- access string 101
- acknowledgement 86
- Acquisition Data form 92
- add button 14
- add network 10
- addressing 121
- AHY 79
- alarm tone 45
- ALLI 103
- Alpha Symbols form 56
- alphanumeric
  - entry 99
  - entry mode 56
  - key 91
- Alt key 7
- ANI
  - beep 34
  - decoding 41
  - DTMF mode transmission 56
  - leading 36
  - random 37
  - sequence 34
  - suppression time 37
  - trailing 37
- ANN
  - fleet call string 126
  - group number 89
  - Interfleet form 81
  - numbering 84
- application installation 3

- arrow keys 7
- audible alert 43
- audible indicators 109
- auto acknowledge
  - beep 35
  - delay time 38
  - format 33
  - identity 33
- auto quiet timer 27
- automatic caller identification 41
- AUX line 29, 60, 107
- auxiliary
  - latching 107
  - momentary 107
- auxiliary key 29
  - emergency call 43
  - one touch call 60
  - operation 59

## B

- background hunt 79, 81
- background search 79, 81
- backlighting 54, 61, 98
- BCD channel selection 48
- BCD polarity 48
- birdie channel 52
- birdie killer 52
- bits per character 94
- broadcast 86
- broadcast call 127

## C

- C1 to C4 keys 99
- call
  - abbreviated 127
  - broadcast 127
  - clear 101
  - conference 127
  - despatcher 127
  - diversion 41, 104, 127
  - diversion channel 41
  - diversion status 41, 43
  - emergency 101, 127
  - external alert 106
  - handsfree initiation 108
  - indicators 28

- interfleet 103
- key 29, 61
- one touch 60
- preset 99
- priority 127
- PTT initiation 108
- queue 96, 104
- queuing 41, 105, 127
- single press PTT 108
- SOS 101
- status 127
- string 100, 107
- string ECR 101
- time limit 86
- tone 110
- unit status display 41
- Call Options form 102
- callback 104
- caller identity 32
- caption position 11
- car
  - horn 105
  - lights 105
  - to car dialling length 38
- CCI Setup form
  - conventional radios 57
  - trunked radios 94
- CCIR 36
- change data
  - check box 14
  - combo box 13
  - grid 14
  - text box 13
- channel
  - birdie 52
  - hunting type 80
  - identity 46, 53, 60, 60
  - key 29, 49, 60
  - mode 47
  - power level 75, 88
  - selection keys 60
  - signalling 88
  - spacing 47, 75
  - start 74
  - stop 74
  - trunked 119
  - trunked blocks 74
- Channels form 46
- chassis serial number 25
- check box 14
- checksum 131
- clear temporary scan allocation 51
- codeword 76, 78, 96, 119

- COM port 3, 57
- combo box 13
- communication port 11
- compatibility
  - options boards 71
- comprehensive hunt 79, 80, 81
- computer controlled interface (CCI)
  - conventional radio setup 57
  - data transmission 57
  - installation 25
  - trunked radio setup 94
- conference call 127
- contents and index 11
- continuous 80
- control category 92
- control channel 75, 76, 92, 92, 119, 120
- control channel priority 93
- control head
  - Selcall dialling 38
  - signaling preset select 31
- control status
  - activate stun 42
  - call diversion 43
  - digits 41
  - priority call 42
  - quiet interrogation 42
  - user alert 43
- conventional channels 88, 127
- Conventional Channels form 87
- copy 9, 15
- copying fields 15
- corrupt file 131
- CPSX 121
  - call strings 126
  - dialling 83
  - dialling strings 126
  - fleet size 124
  - identity 125
- create new database 5
- CTCSS
  - assign to channel 47
  - concept 114
  - filter 30
  - frequency range 114
  - reverse tone burst 31
  - settings 30
- cut 8

## D

- data
  - call time limit 87

- calls 95, 104
- external alert on call 106
- length (CCI) 58
- rate 94
- tone on call 110
- transmission (CCI) 57

Data Parameters form 95

database

- new 5

DCS

- assign to channel 47
- description 114
- filter 30
- frequency range 114
- polarity 30, 30, 114
- settings 30

default

- access level 6, 11
- alphanumeric symbol name 57
- channel name 47
- data 5
- mode 26
- power-up mode 26
- preset label 31
- scan group name 49

default SDM call string 96

deferred calling 40

delete 9

delete button 14

delete network 10

dependant fields 13

despatcher 96

- direct 105
- enable radio as 104
- key call string 107
- key long press 107
- key short press 107
- number 86
- queue 105
- request callback 127

diagnostics 109

dialling

- abbreviated 102
- DTMF 26, 54, 63, 109
- group 40
- length (Selcall) 38
- manual DTMF 55
- scheme 83
- Selcall 26
- Selcall group tone 40

dim 98

direct despatcher 105

disabled fields 13, 131

- disconnect messages 78
- diversion
  - channel 41
  - description 41
  - status 41
  - trunked call 104, 127
- don't disturb 103, 127
- drag and drop 15
- DTMF
  - ANI transmission 56
  - dialling 109
  - dialling type 62
  - installation 25
  - interdigit Tx hold time 55
  - manual dialling 55
  - minimum intertone gap 55
  - minimum tone duration 55
  - one touch call 60
  - PTT as shift key 56
  - redial transmission 55
  - string 55
  - timeout 109
  - transmit key up delay 55
- dual port 94
- DZVEI 36

## E

- economy mode 54, 61
  - backlighting level 98
  - ignition off 98
  - ignition on 98
- ECR call clear 101
- ECR call string 101
- Edit menu 8
- EEA 36
- EIA 36
- emergency
  - auxiliary key activates 60
  - call 43, 127
  - call time limit 87, 101
  - callout 45
  - cycling 45, 102
  - external alert 106
  - ident 86
  - mode 43
  - mute received audio 44
  - number for trunked radios 86
  - prefix 86
  - receive time 45
  - retries 101
  - RMR sequence 44
  - Selcall sequence 35, 44

- tone 110
- transmit time 45
- Enhanced Scan form 51
- enhanced scanning 25, 48, 51
  - clear user changes 51
  - grid 52
  - ID 52
  - type 52
- enter key 55, 62
- equipment supplied 3
- error
  - reset after 109
- Esc key 7
- Excel 15
- exit 8
- external alert
  - auxiliary key activates 60
  - data call 106
  - delay 38
  - duration 38
  - emergency calls 106
  - group calls 106
  - include calls 106
  - individual calls 106
  - level 38
  - signal pattern 105
  - speech calls 106
  - status calls 106
  - time delayed 105
  - time on 105
  - user selectable 61
- External Alert form 105
- External Call form 101
- external mute 61

## F

- fast PTT 29
- feature set 24, 70
- FFSK 119
- field
  - can't enable 131
  - can't find 131
  - data 13
  - disabled 13
- File menu 7
- files
  - recent 8
- fleet
  - ANN interfleet 81
  - call string 126
  - CPSX large 124
  - CPSX medium 124

- CPSX small 124
- CPSX Tiny 124
- dialling string 126
- group number 84
- highest group number 84
- highest individual number 84
- highest number 100
- individual number 84
- MPT 1343 122
- number 100
- partitioning parameter. See FPP
- prefix 84, 100
- restrict calls 91
- settings 68, 83
- type 100
- Fleet Identity form 83
- Fleet Parameters form 86
- footswitch 71
- forms tree 4, 6, 6, 131
- FPP 85
- frequency band 25, 47, 70
- full queue 105
- function 29
- function key 29
  - call string 107
  - latching 107
  - mode 107
  - momentary 107
- function menu. See user function menu

## G

- green indicator 6, 6, 9
- greyed out fields 13, 131
- grid 14
- grids
  - copy 15
  - drag and drop 15
- group
  - attributes 91
  - call string 126
  - dialling 40
  - dialling string 126
  - format 38
  - interfleet call 100
  - join busy 104
  - permanent 91
  - scan 91
  - select 91, 91
  - selectable 91
  - selectable + scan 91
  - selective dialling 40
- group calls



- external alert [106](#)
- interfleet [103](#)
- membership [90](#)
- restrict [92](#)
- tone [110](#)
- group number
  - CPSX [124](#)
  - MPT 1343 [123](#)

## H

- handsfree
  - call initiation [108](#)
  - enable [71](#)
- handshaking mode [94](#)
- handshaking mode (CCI) [58](#)
- hardware
  - computer controlled interface (CCI) [25](#)
  - DTMF [25](#)
  - signaling [25](#)
- Help menu [11](#)
- hidden channels [50](#)
- hide error messages [11](#)
- hide messages [11](#)
- home channel [117](#), [118](#)
- home zone [93](#)
- hookswitch [28](#), [48](#), [50](#)
- hookswitch monitor [88](#)
- HORN line [61](#)
- hunting
  - background [79](#), [81](#)
  - comprehensive [79](#), [80](#), [81](#)
  - control channel priority [93](#)
  - non applicable channels [80](#)
  - normal [81](#)
  - normal channels [80](#)
  - preferential [93](#)
- Hunting Parameters form [79](#)
- HUSH line [61](#)

## I

- ident
  - MPT 1327 [122](#)
- identity [125](#)
  - auto acknowledge [33](#)
  - caller [32](#), [33](#), [35](#), [41](#)
  - channel [41](#), [46](#), [50](#), [60](#)
  - number [121](#)
  - receiver [32](#), [33](#), [34](#), [35](#), [39](#), [40](#), [44](#), [57](#)
  - repeater [32](#), [33](#), [39](#)
  - scan group [49](#), [60](#)

- Selcall [32](#)
  - Tx call [39](#)
- IF bandwidth [48](#)
- ignition off
  - economy mode [98](#)
- ignition on
  - economy mode [98](#)
- import network [8](#), [69](#)
- include calls [106](#)
  - tone [110](#)
- include request [78](#)
- include timer [79](#)
- individual calls
  - external alert [106](#)
  - restrict [91](#)
- individual interfleet call [100](#)
- INFO field [76](#)
- insert button [14](#)
- install application [3](#)
- installed options [71](#)
- Interface Options form [108](#)
- interfleet
  - ANN [81](#)
  - call [103](#)
  - call string [126](#)
  - calls [100](#)
  - CPSX [125](#)
  - dialling string [126](#)
  - group calls [100](#), [103](#)
  - individual calls [103](#)
- internal alert duration [38](#)
- International group format [38](#)
- internet [12](#)
- internet help [19](#)
- interrogate radio [10](#)

## J

- join busy group [104](#)

## K

- key
  - # [40](#)
  - \* [40](#)
  - auxiliary [29](#), [43](#), [59](#), [60](#)
  - call [29](#), [61](#)
  - channel [29](#), [47](#), [48](#), [49](#)
  - enter [55](#)
  - function [29](#)
  - memory [60](#)
  - monitor [27](#), [113](#)

- PTT 28, 56
- Key Settings form
  - conventional radios 59
  - trunked radios 107
- keypress confidence tones 109

## L

- LA 76
- label
  - alpha symbol 57
  - preset call 99
  - signaling preset 31
  - status 43, 97
- license 131
- line interface 72
- list of recent files 8
- LM1 79
- LM2 79
- LM3 79
- lookup table 100
- LZ 76

## M

- main window 4
- MAP27 72, 94
- memory key 51, 51, 60, 60
- menu commands 7
- menus 4
- MEP 85
- microphone socket 3
- Miniaturisation Extent Parameter. See MEP
- mobiles support 12
- mode
  - alphanumeric entry 26, 56
  - channel entry/selection 26, 47, 49
  - DTMF dialling 26, 55
  - emergency 43
  - power-up 26
  - scan 48
  - Selcall dialling 26
  - status entry 26
  - user function menu 26
- model 10
- monitor
  - deactivation 27
  - description 116
  - hookswitch 88
  - hookswitch activation 28
  - key 113
  - key press 28

- mute disable 27
- power-up state 27
- PTT opens 28
- radio monitor reset 33, 44
- Selcall call activates 27
- MPT 1327 90, 120
- MPT 1327 numbering 122
- MPT 1327 prefix 122
- MPT 1343 83, 120
- MPT 1343 identity 125
- MPT 1343 number 89
- MPT 1343 numbering 122
- multiple networks 68, 127
- multiple registration 76, 78
- mute
  - disable 27
  - selective call 27, 116
  - signaling 113
  - subaudible signaling 27, 113, 116

## N

- name
  - alphanumeric 56
  - channel 47
  - scan group 49
- NATEL 36
- navigate
  - forms tree 6
  - menu commands 7
  - radio model toolbar 5
- ND1 78
- ND2 78
- NE 78
- Network Identity form 75
- Network menu 10
- network operator service call 103
- network settings 68, 74
- networks
  - CPSX dialling 83
  - identity code 75
  - importing 69
  - MPT 1343 83
  - multiple 68, 127
  - multiple registration 76, 78
  - name 72
  - national 75, 93
  - Nokia Actionet 83
  - Nokia ANN 83, 84
  - Number Presets 83
  - radio registration 108
  - regional 75, 93

- Regionet 43 83
  - template 68
  - type 75
  - ZVEI 83
- new database 5
- next network 10
- NI 78
- NIC. see Networks - Identity Code
- noise 113
- Nokia Actionet 83
- Nokia ANN 81, 81, 89, 121, 126
- non applicable hunt channels 80
- non-emergency call requests 78
- normal backlighting level 108
- normal hunt 81
- normal hunt channels 80
- NPD 96, 127
- NR 78
- NS 79
- NT 78
- Number Presets 83, 121
- NW 78

## O

- off hook scan 50
- off hook scanning 48
- one touch call 60
- one touch calls 60
- online help 11, 19
- open 7
- operation
  - scan 48
- option boards 71
  - compatibility 71
- options 11
  - computer controlled interface (CCI) 25
  - connector 60, 61
  - DTMF 25
  - signaling 25

## P

- PABX 103, 122
- parity 94
- parity type (CCI) 58
- paste 9
- permanent group 91
- polarity 114
- polling 117
- power level 48

- Power Saving form
  - conventional radios 54
  - trunked radios 97
- power-up
  - message 26, 72
  - mode 26
- preferences 11
- preferential hunt 93, 93
- prefix 84
  - MPT 1327 122
- preset call
  - call string 100, 127
  - dialling string 127
  - function key 107
  - label 99
  - number 99
- Preset Calls form 99
- preset label 31
- presets
  - signaling 31
  - subaudible signaling 114
- pressel off 76
- pressel on 76
- previous network 10
- primary priority scan 48, 52
- print 8
- printer settings 8
- priority call 120, 127
- priority call detection 42
- Program button 5
- program radio 5, 9, 131
- programming database 4
- programming sequence 68
- PSTN 103, 122
- PTT 108, 108
- PTT key 28, 29, 29, 56
- PZVEI 36

## Q

- queue 127
- queue key 91
- queuing 105
- quiet interrogation 42
- quiet state 116

## R

- radio
  - chassis serial number 25
  - communications ports 57

- feature set 24, 70
- frequency band 24, 25, 69, 70
- hardware options 24, 69
- identification 25
- information 69
- language 72
- model 24, 24, 46, 59, 69, 70
- monitor function 26, 27
- part number 25, 69, 70
- power-up message 26, 72
- power-up mode 26
- program 5, 131
- programming 24, 70
- programming cable 3
- programming database 4
- read 4, 131
- registration 108
- unit ID 89
- unit settings 89
- user function menu 61

Radio menu 4, 5

radio model 4, 5, 10

radio model toolbar 5

radio monitor reset

- acknowledge 34
- alert 38
- sequence 34

Radio Unit ID form 89

radio unit settings 68

range 13

Read button 4

read radio 4, 9, 131

receive baud rate (CCI) 58

Receive Monitoring form 26

received call queuing 41

receiver identity 32

recent file list 8

Regionet 43 83

register 108

registration 76

remote control 57

repeat button 14

repeater

- identity 32, 39
- sequence 39
- talkaround 29

reset after error 109

reset to defaults 7

restrict calls 91

reverse tone burst 31

revert form 9

revert to saved 8

RQE 78

RX

- channel frequency 87
- trunked channel blocks 74

Rx

- audio sensitivity 48
- call sub-sequence decoding 41
- channel frequency 47
- CTCSS/DCS 47
- CTCSS/DCS filter 30
- DCS polarity 30
- decode sequence 34
- format 33
- start 74

## S

save 8

save as 8

scan

- channels 48
- description 116
- dual priority 49
- enhanced 25, 48, 51
- group 48, 49, 118
- hold time 48, 48
- off hook 48, 50
- polling 51
- primary priority 48, 52
- priority 49
- secondary priority 48, 52
- voting 49, 50

scan group 91

- identity 49, 60
- membership list 50
- name 49
- type 49
- user reprogram 50

scan group hold time 50

Scan Group Members tab 49

Scan Groups form 48

Scan Groups tab 50

scrambler 60

scrambler module 71

scroll keys 99

SDM 72, 95, 104

secondary priority scan 48, 52

Selcall

- alpha symbols 57
- auto acknowledge format 33
- automatic caller identification 41
- call key 61
- caller identification 35

- description 114, 115
- emergency sequence 35
- installation 25
- internal alert 38
- lead in delay 36
- lead in tone 36
- mute 39, 113
- one touch call 60
- PTT calls 39
- radio monitor reset 33
- repeater sequence 48
- RMR sequence 44
- Rx format 33
- tone period 36
- tone set 36
- tone set table 37
- Tx call identity 39
- Tx format 32
- Selcall Control Status Definitions form 41
- Selcall Features form 40
- Selcall Identity and Setup form 32
- Selcall Identity tab 32
- Selcall multi-tone. See Selcall 114
- Selcall Setup tab 36
- select all 9
- selectable + scan group 91
- selectable group 91
- selection keys
  - channel 60
- selective call mute 27, 113, 116
- serial connector 3
- serial port 3
- short data messages. See SDM
- short status display 62
- show general dialogs 11
- signal strength 41, 117
- signaling
  - alpha symbol 57
  - CTCSS 114
  - DCS 114
  - installed 25
  - override 114
  - presets 31
  - Selcall 25, 114
  - sqelch 113
  - subaudible 114
- signalling
  - channel 88
- Signalling Interface 72
- Sigtec group format 38
- SIL 76
- single port 94
- single press 108
- site select 81
- slot timing 76
- slotted Aloha 120
- software version number 4, 5
- SOS
  - call time limit 101
  - calls 101
  - retries 101
  - Rx time 102
  - Tx time 102
- SOS mute 102
- speaker 113
- Specifications form
  - conventional radios 24
  - trunked radios 69
- spreadsheet 15
- sqelch
  - description 113
  - disable 113
  - override 28, 113
  - threshold 113
- startup position 11
- status 104, 127
  - bar 4
  - burst 33
  - calls 97
  - digit 33, 41, 43
  - external alert 106
  - identity 43
  - key 95
  - label 43
  - message 43, 57, 60
  - short display 62
  - tone 110
  - value 97
  - variable 34, 35, 39, 44
- Status Labels form 97
- stop bits (CCI) 58
- stun 42
- subaudible signaling
  - assign to channel 47
  - description 114
  - mute 27, 113, 116
  - override 31
  - presets 114
- Subaudible Signaling Presets tab 31
- Subaudible Signaling Setup form 30
- Subaudible Signaling tab 30
- SYNC 75
- SYS code 93
- system requirements 3

## T

- TA 79
- tail time 41
- Tait Data Protocol. See TDP
- taitworld 12
- TB 79
- TC 78
- TD 78
- TDP 96
  - acknowledge 96
  - contact wait 96
  - group wait 96
  - synchronisation 96
  - timer DCI 96
  - tone 96
- technician 104
- telephone plug 3
- template 24, 70
- test mode 109
- text box 13
- TGG timer 95
- TGI timer 95
- TH 79
- third tone monitor reset 40
- TI 79
- timer 86
- time-shared 80
- TJ 78
- TL 79
- TN 78
- toggle 28, 60
- tone
  - data calls 110
  - emergency calls 110
  - group calls 110
  - include calls 110
  - incoming call 109
  - individual calls 110
  - keypress 109
  - level 109
  - set 109
  - speech calls 110
  - status calls 110
  - suppress all 109
- tone blanking 38
- tones 96
- toolbars 4
- Tools menu 11
- TP 79
- traffic channel 78, 119
- transmit 29
  - baud rate (CCI) 58
  - duration 78
  - inhibit 29
  - lockout 29
  - timer 28, 29
- Transmitter Setup form 28
- transparent mode (CCI) 58
- trunked channel blocks 81
- Trunked Channel Blocks form 74
- trunked mode 109
- trunking
  - address 121
- trunking network 92
- trunking system 119
- TSC 77, 78, 87, 119, 120
- TT 78
- TW 79
- Tx
  - call identity 39
  - call sequence 39
  - channel frequency 47, 88
  - CTCSS reverse tone burst 31
  - CTCSS/DCS 47
  - DCS polarity 30
  - deviation 48
  - format 32
  - inhibit 29, 88
  - lockout 29
  - power level 48
  - repeater sequence 48
  - Selcall sequence 47
  - start 74
  - timer 29
  - tolerance factor 41
  - trunked channel blocks 74

## U

- UIM 94
- unanswered calls 105
- undo 8
- user function menu 61, 62, 114
- user group select 91, 91
- user groups segregation 114
- user selectable 114
- User Selectable Parameters form 61

## V

- validate form 9
- variable status 34, 35, 39, 44
- version number 4, 5

voice inversion [71](#)  
voting [49](#), [117](#)  
    definition [48](#)  
    lead in delay [50](#), [118](#)  
    polling interval [51](#)  
VOX [71](#)

## W

Web Address [11](#)  
what's this? help [11](#), [13](#), [19](#)  
wide area coverage [117](#)  
wild card tone [34](#)

window state on startup [11](#)

## X

XOFF character [95](#)  
XON character [95](#)

## Z

ZVEI [121](#)  
ZVEI-I [36](#)  
ZVEI-II [36](#)  
ZVEI-III [36](#)

